

# 회로 이론/실습

## 14. 직렬 공진 회로

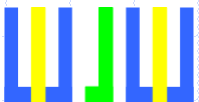

# 14. 직렬 공진 회로

14-1. 목적 및 배경

14-2. 소요 부품 및 장비

14-3. 유용한 공식

14-4. 주파수에 따른 전압

14-5. 공진 주파수

14-6. 대역폭 측정

14-7. 주파수에 따른 위상 변화

14-8. 주파수에 따른 전류 및 임피던스

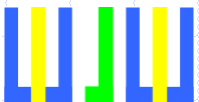

# 14-1. 목적 및 배경

- ✓ 직렬 공진 회로의 특성을 이해한다.
- ✓ 주파수에 따른 전압, 전류, 위상의 변화를 확인한다.
- ✓ 주파수에 따른 임피던스 변화를 확인한다.

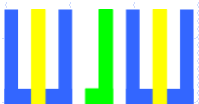

## 14-2. 소요 부품 및 장비

### ✓ 부품

- ✓ 저항 (1/4W) : 10 $\Omega$ , 1k $\Omega$
- ✓ 인덕터 : 10mH
- ✓ 캐패시터 : 0.1 $\mu$ F

### ✓ 장비

- ✓ 브레드 보드
- ✓ 디지털 멀티미터 (Digital Multi-Meter)
- ✓ 직류전원공급장치 (DC Power Supply)
- ✓ 오실로스코프 (Oscilloscope)
- ✓ 신호 발생기 (Function Generator)

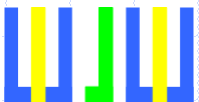

## 14-3. 유용한 공식

✓ 직렬 공진 회로의 공진 주파수

$$f_r = \frac{1}{2\pi\sqrt{LC}}$$

$$A_v(\text{전압이득}) = \frac{V_{out}}{V_{in}}$$

$$Z = R + jX = R + j(X_L - X_C) = R + j\left(2\pi fL - \frac{1}{2\pi fC}\right)$$

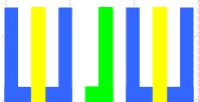

## 14-4. 주파수에 따른 전압

- 다음과 같이 회로를 연결하고, 신호 발생기를 조절하여 주파수 200Hz, 10Vpp 의 정현파가 나오도록 한다.

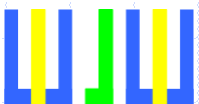
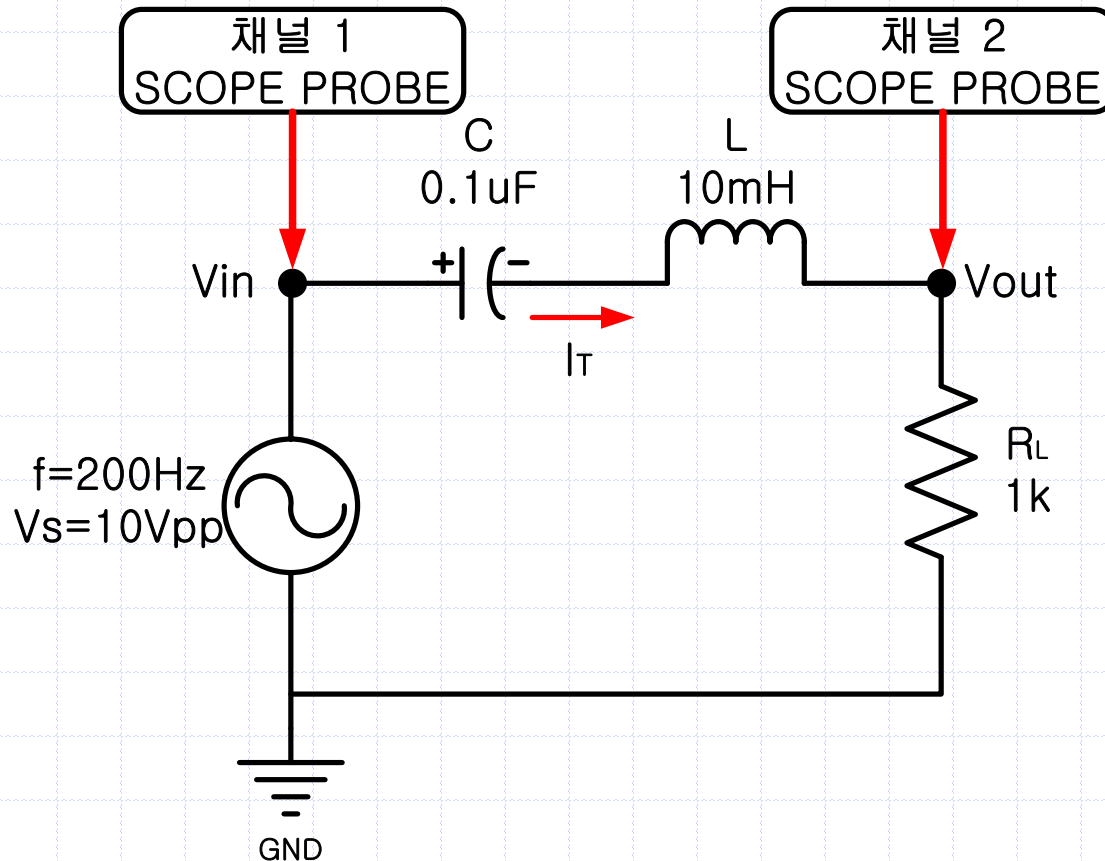

## 14-4. 주파수에 따른 전압

- ✓ 다음과 같이 회로를 연결하고, 신호발생기를 조절하여 주파수 200Hz, 10Vpp 의 정현파가 나오도록 한다.

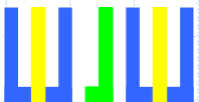
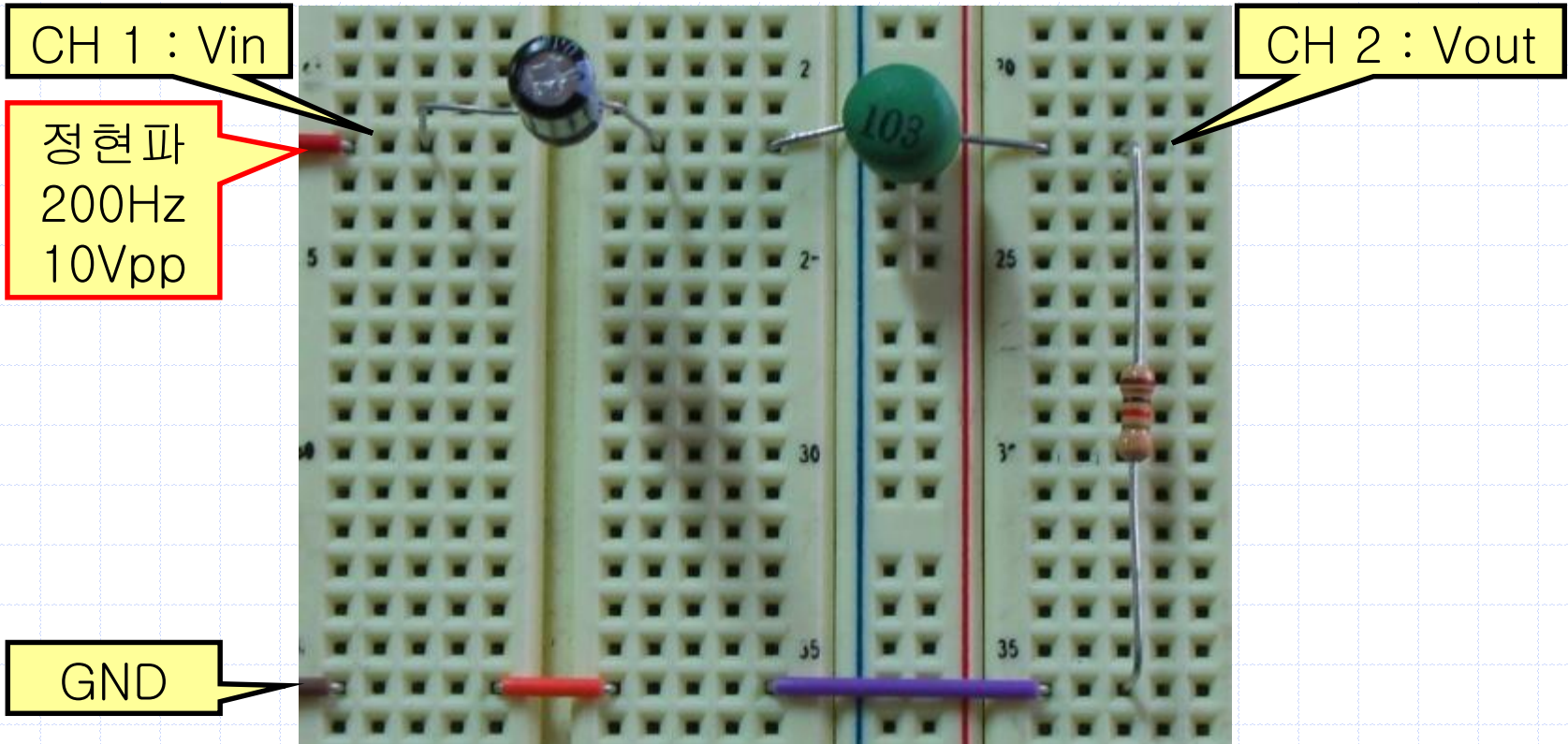

# 14-4. 주파수에 따른 전압

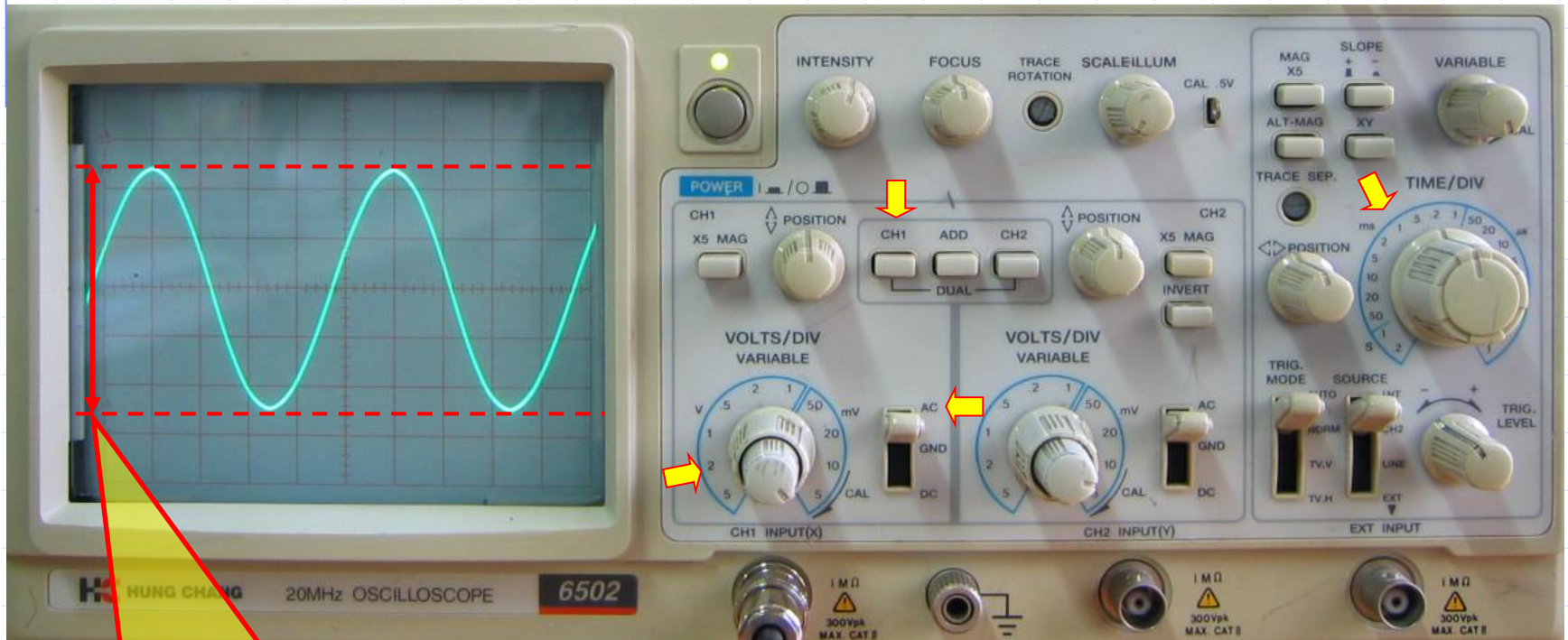
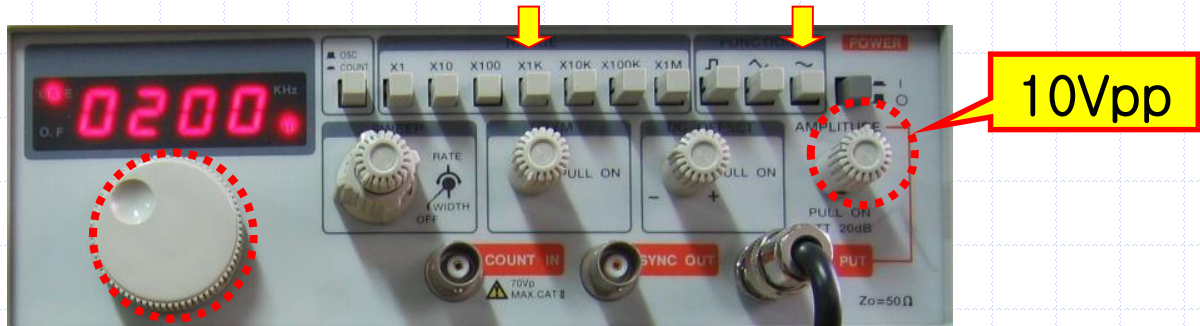

5칸 X 2V/DIV = 10Vpp



# 14-4. 주파수에 따른 전압

- ✓ 오실로스코프의 CH 1 을 이용하여 입력 전압 ( $V_{in}$ ) 을 측정하고, CH 2 는 출력 전압 ( $V_{out}$ ) 을 측정한다.

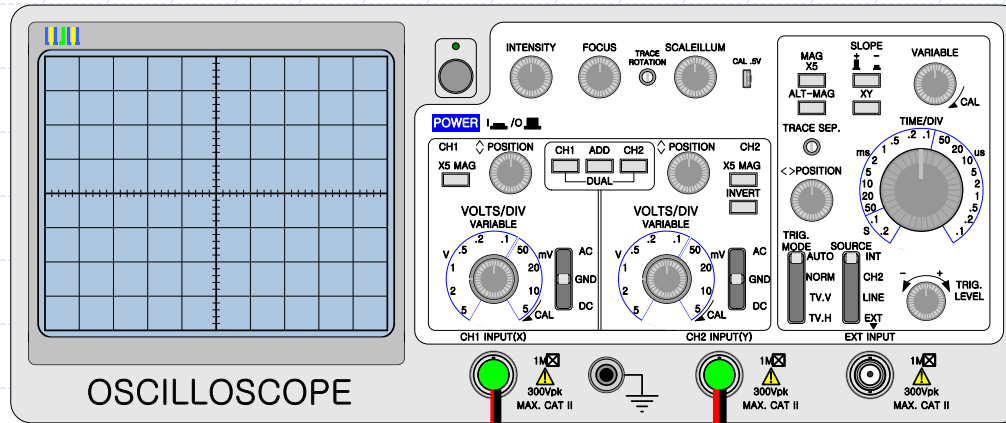

CH 1 :  $V_{in}$

CH 2 :  $V_{out}$

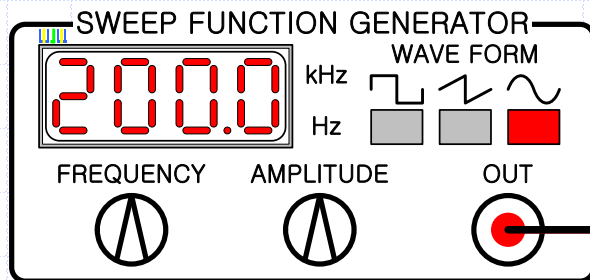

$f=200\text{Hz}$ ,  $10\text{Vpp}$

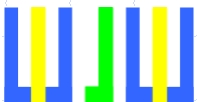
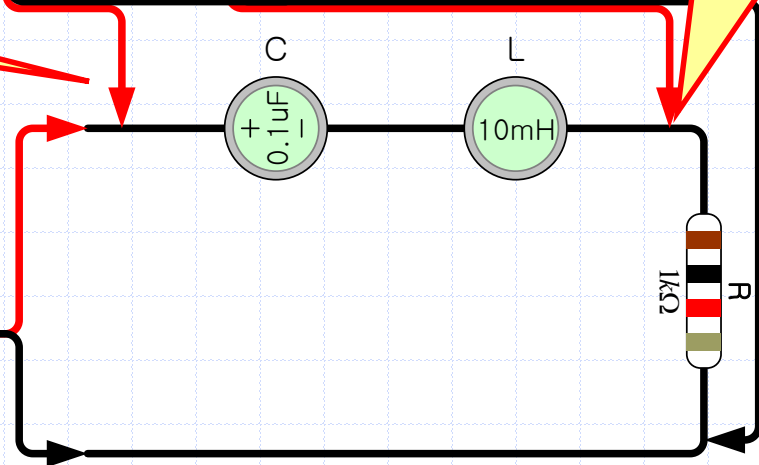

# 14-4. 주파수에 따른 전압

✓ 주파수 : 200Hz

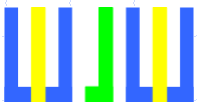
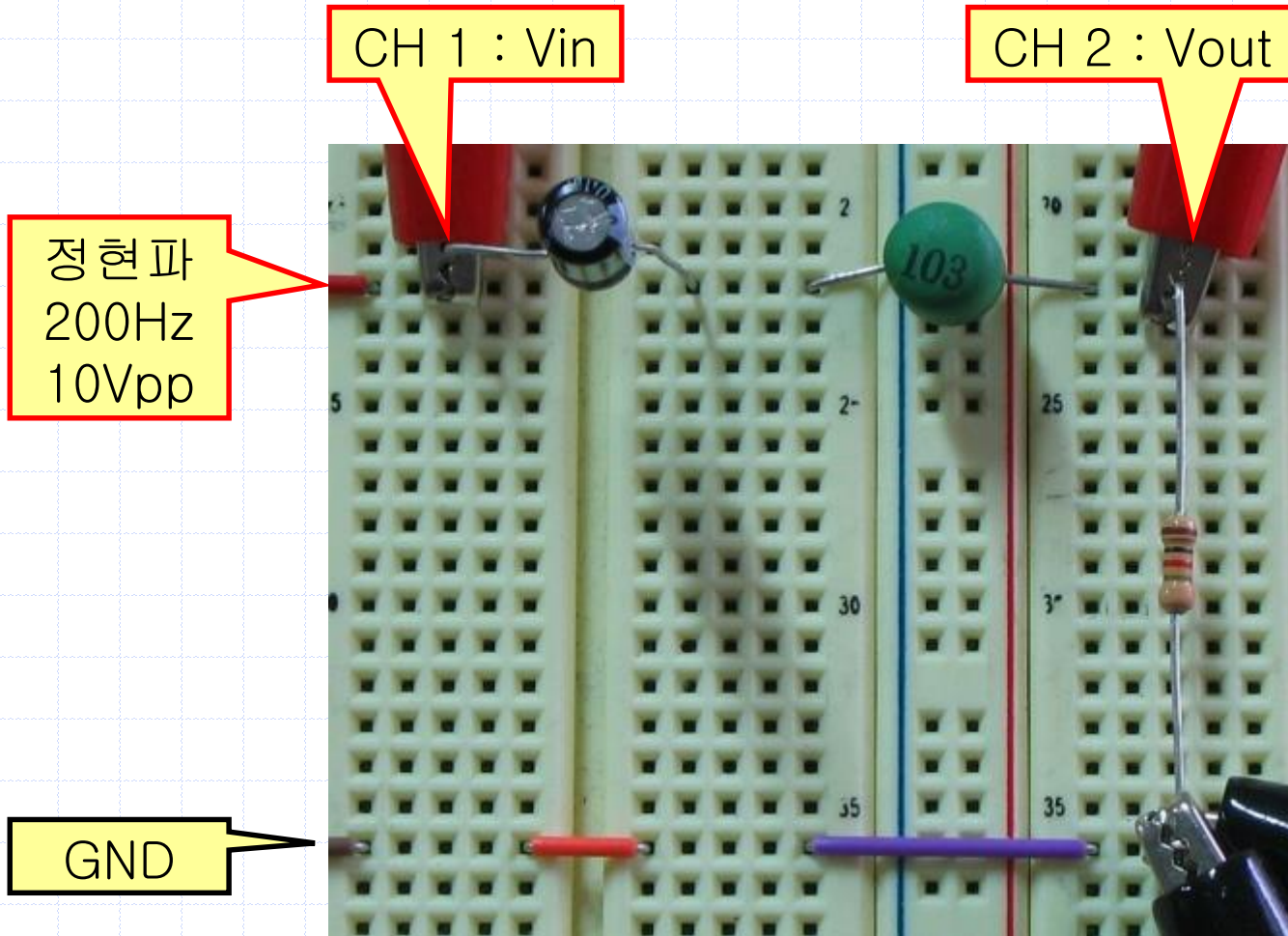

# 14-4. 주파수에 따른 전압

✓ 주파수 : 200Hz

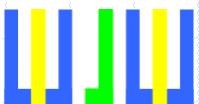
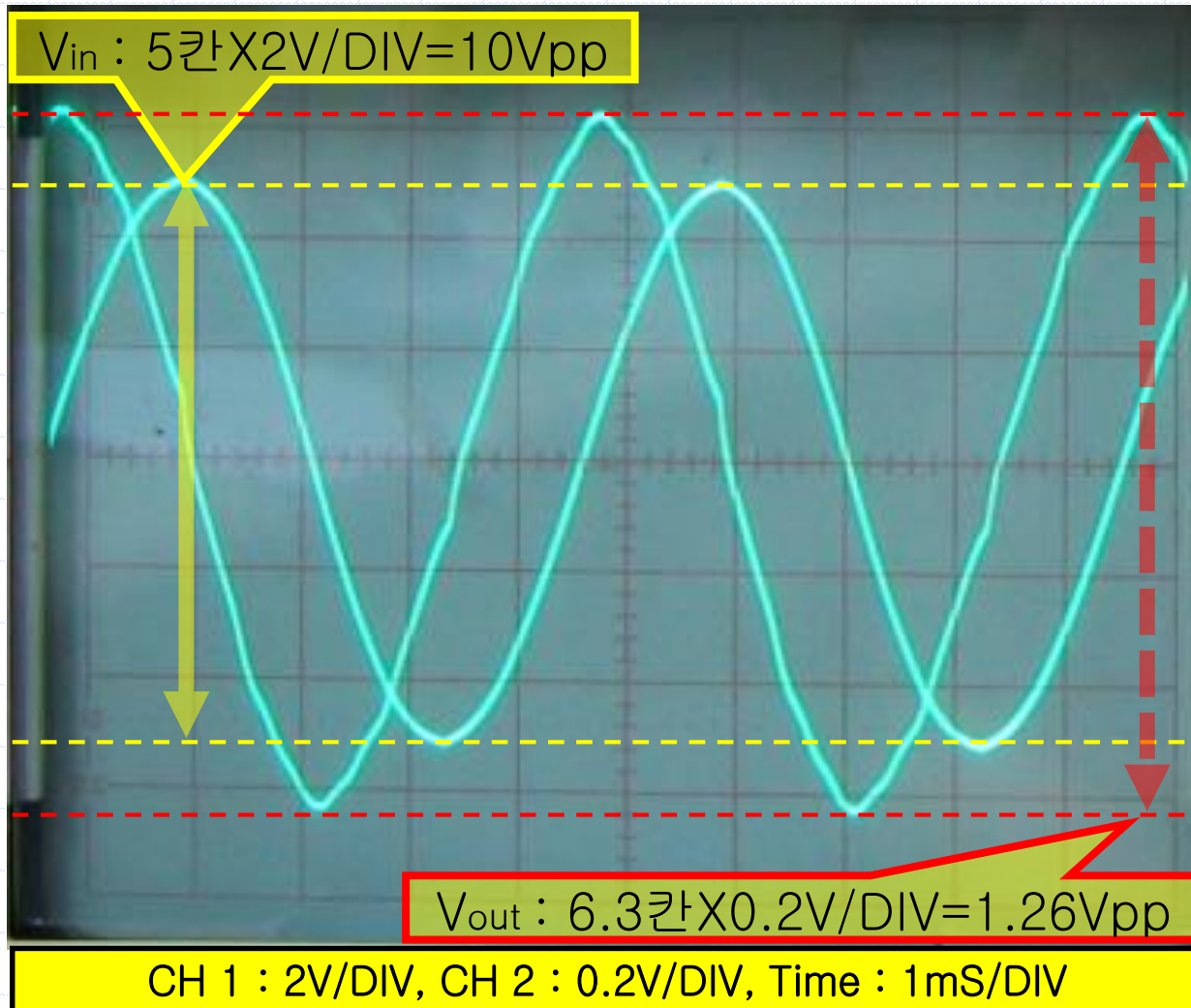

# 14-4. 주파수에 따른 전압

✓ 주파수 : 500Hz

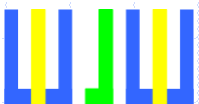
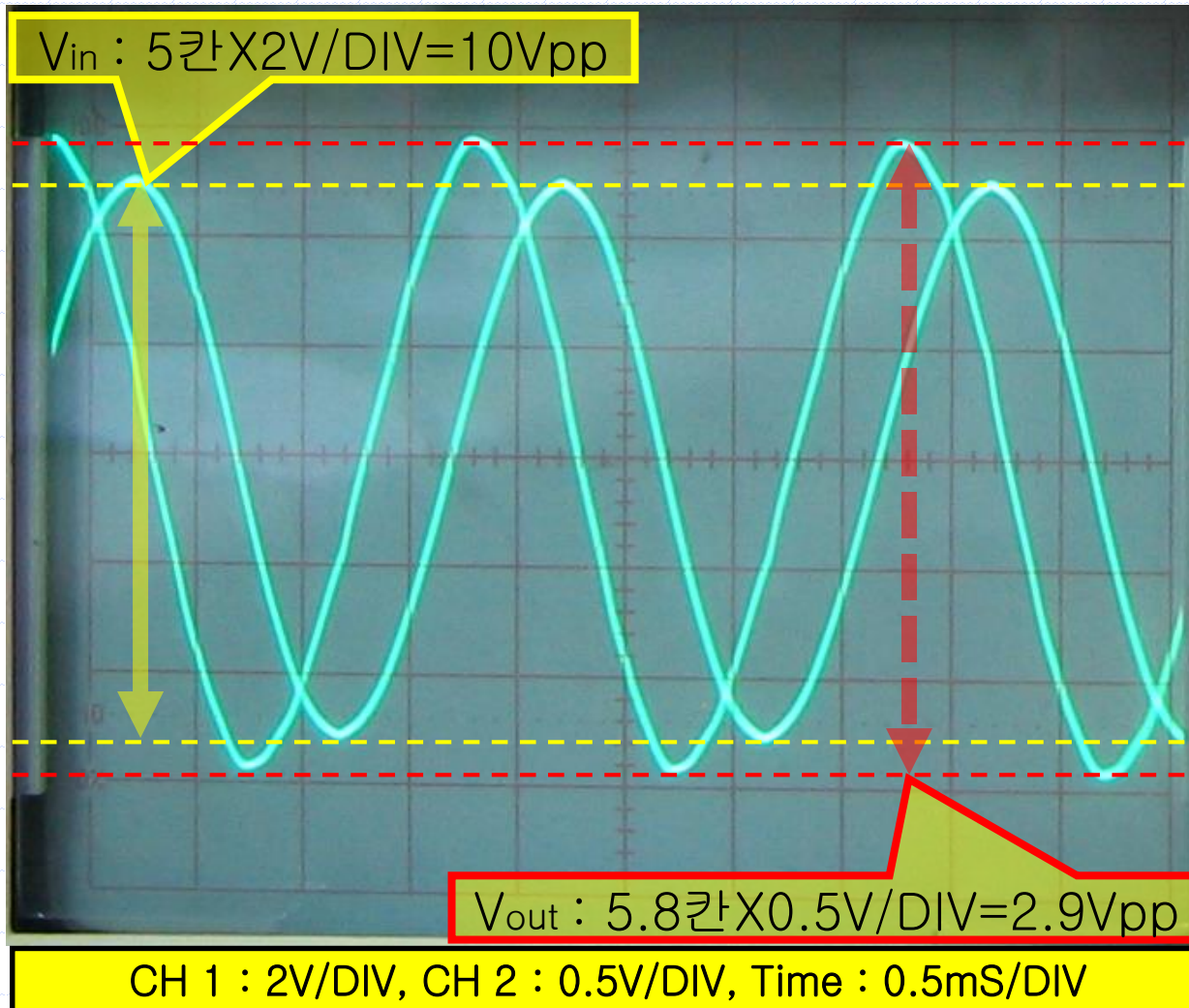



# 14-4. 주파수에 따른 전압

✓ 주파수 : 1kHz

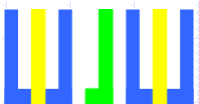
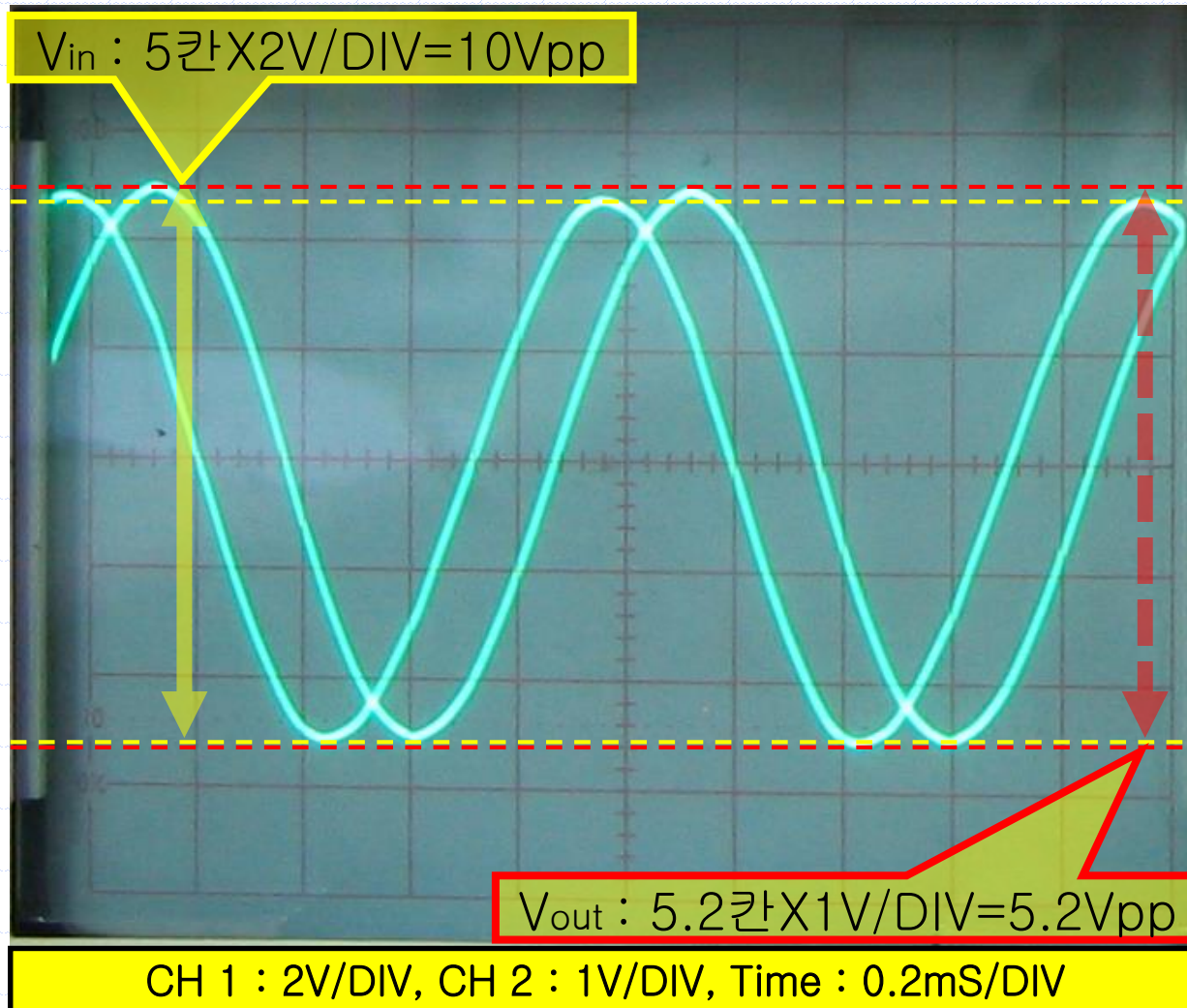

# 14-4. 주파수에 따른 전압

✓ 주파수 : 2kHz

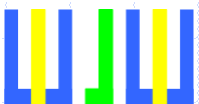
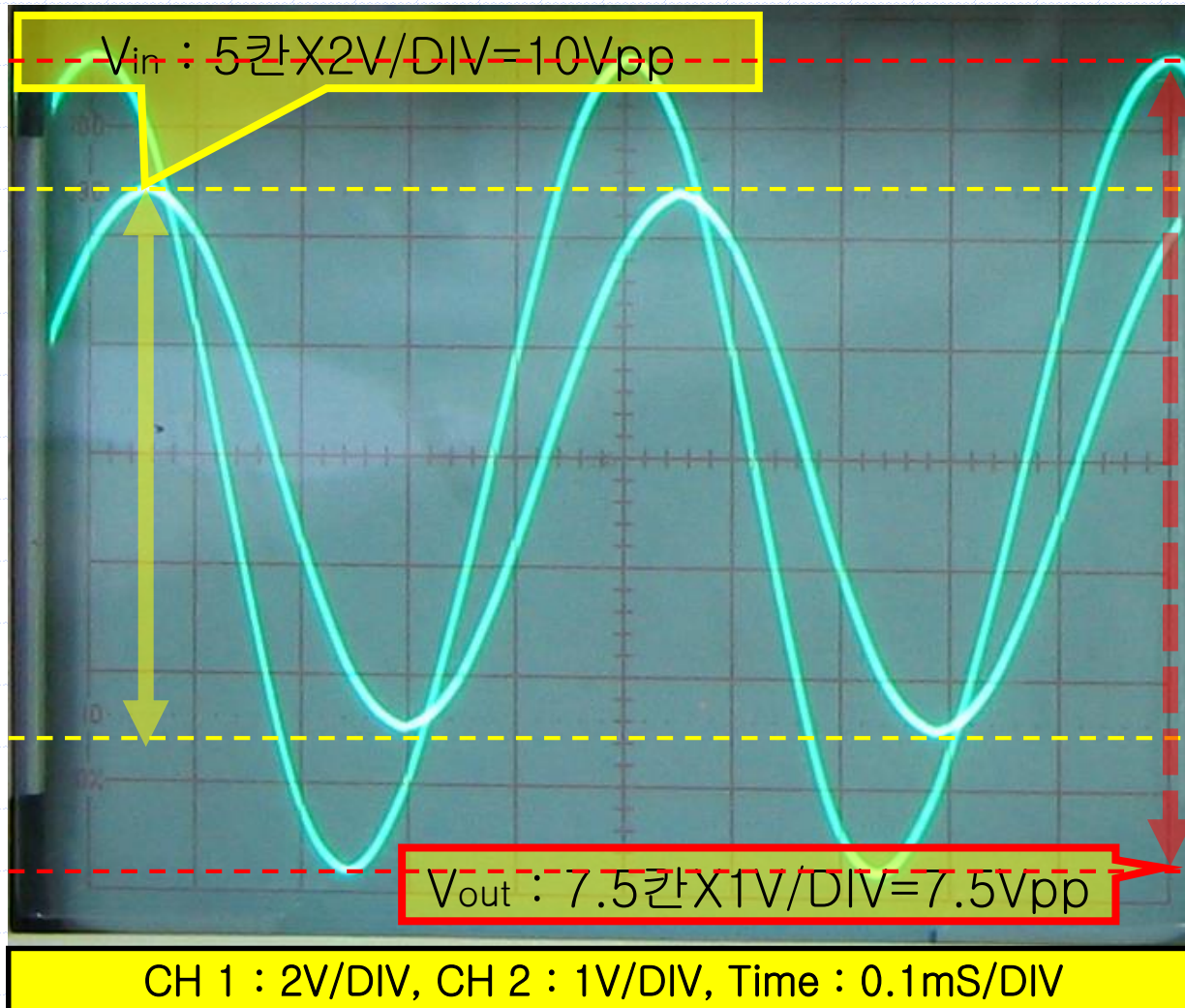

# 14-4. 주파수에 따른 전압

✓ 주파수 : 3kHz

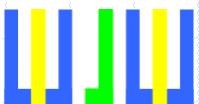
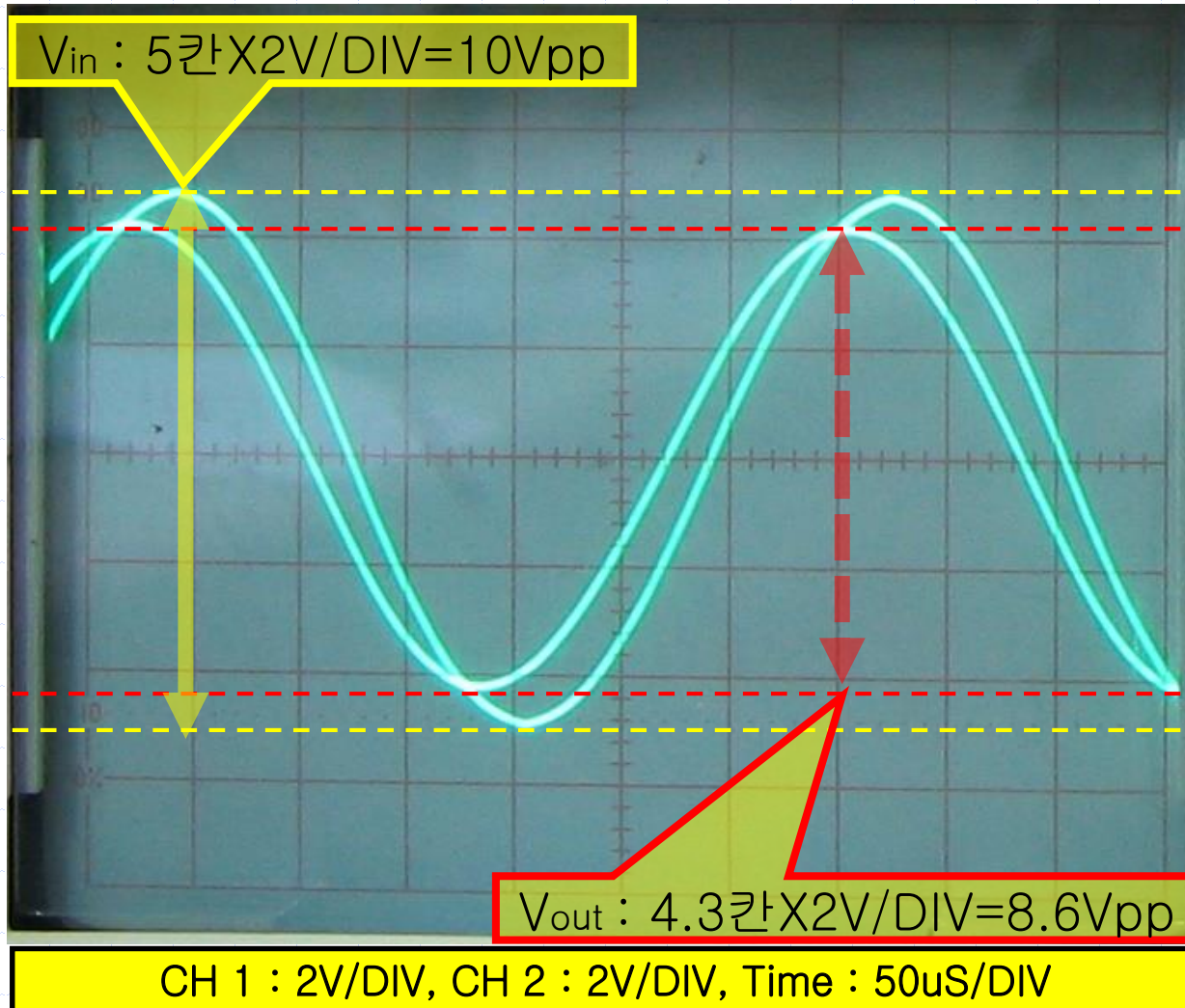



# 14-4. 주파수에 따른 전압

✓ 주파수 : 4kHz

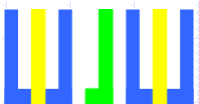
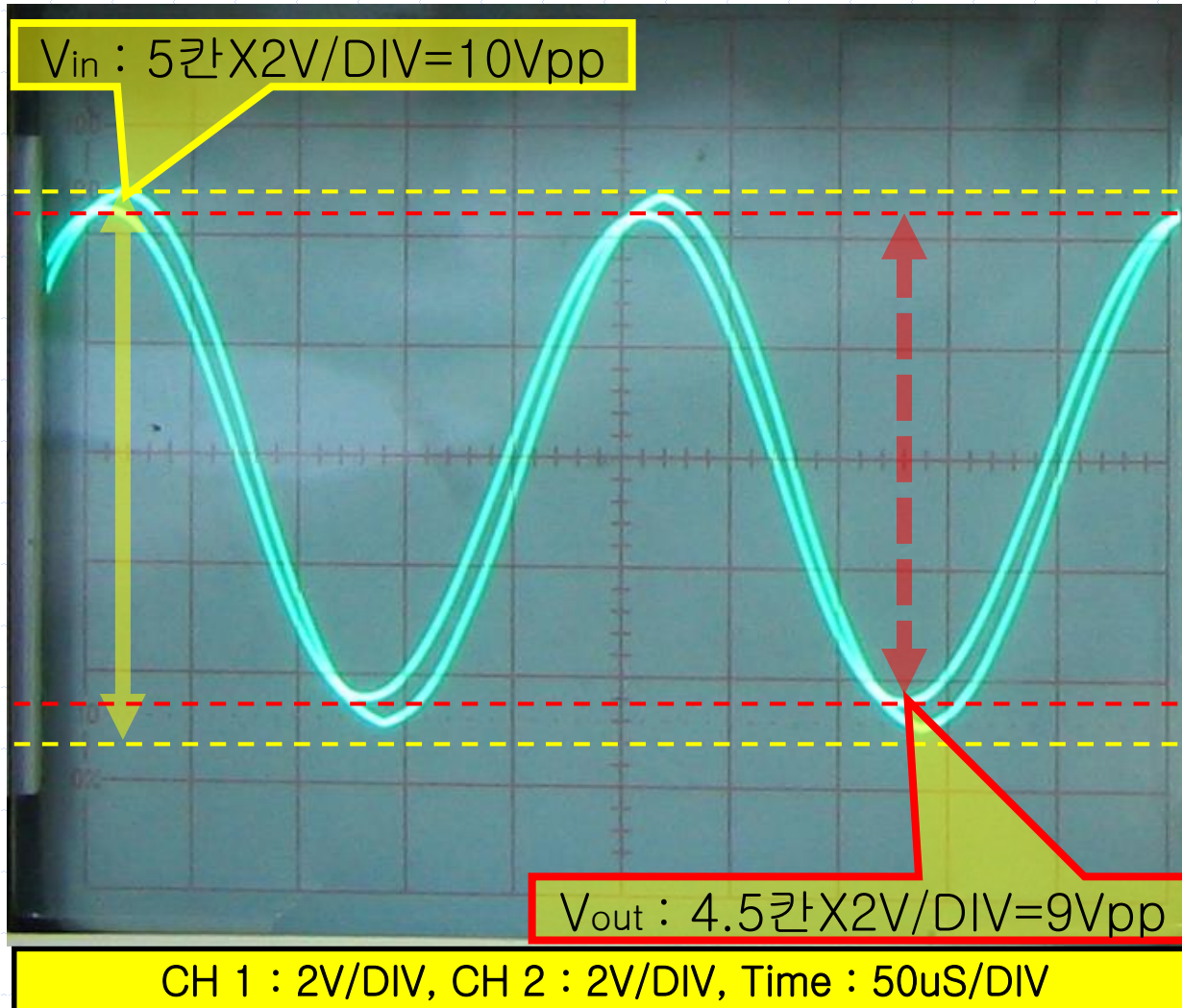



# 14-4. 주파수에 따른 전압

✓ 주파수 : 5kHz

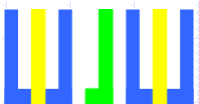
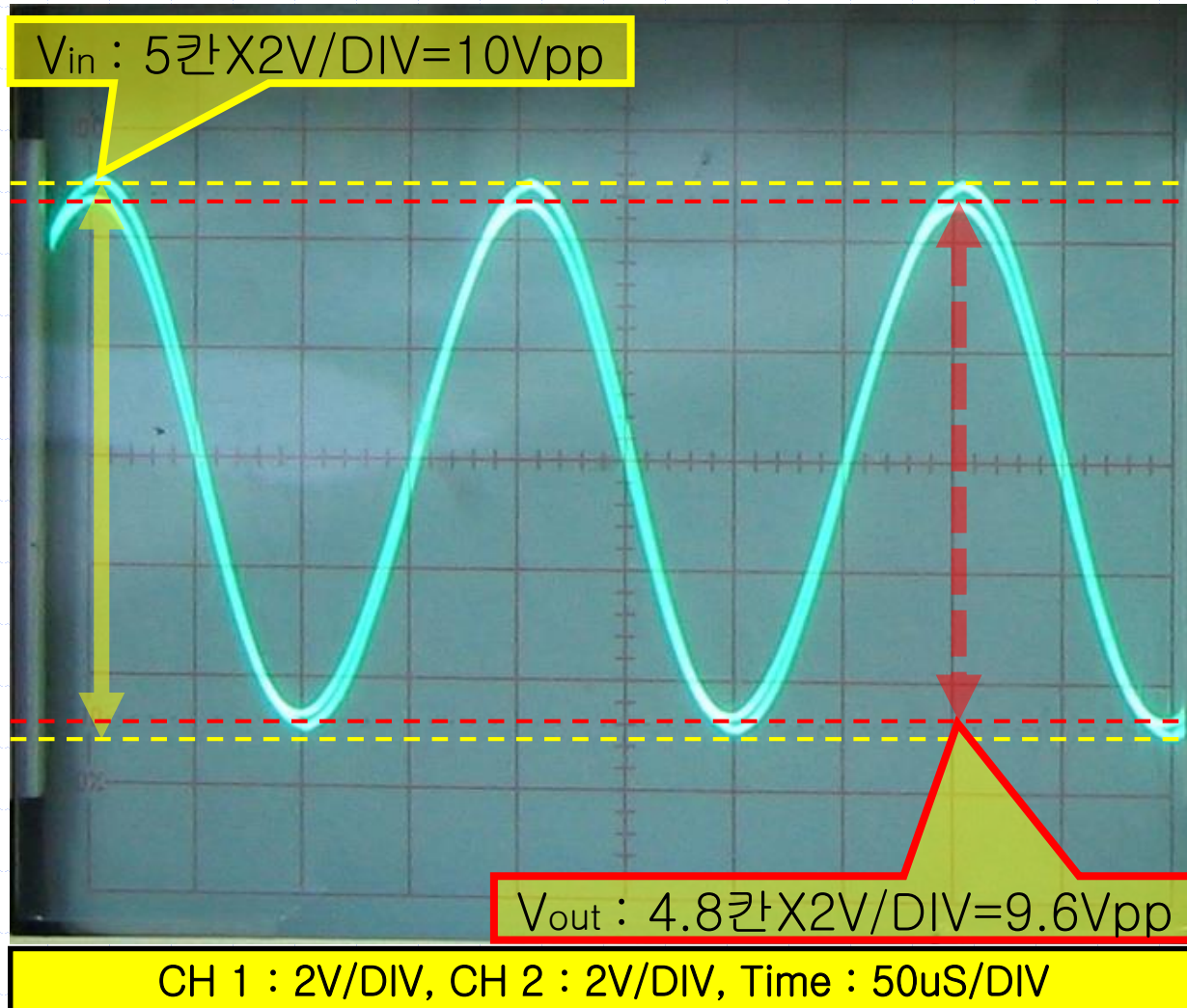

# 14-4. 주파수에 따른 전압

✓ 주파수 : 6kHz

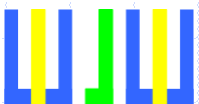
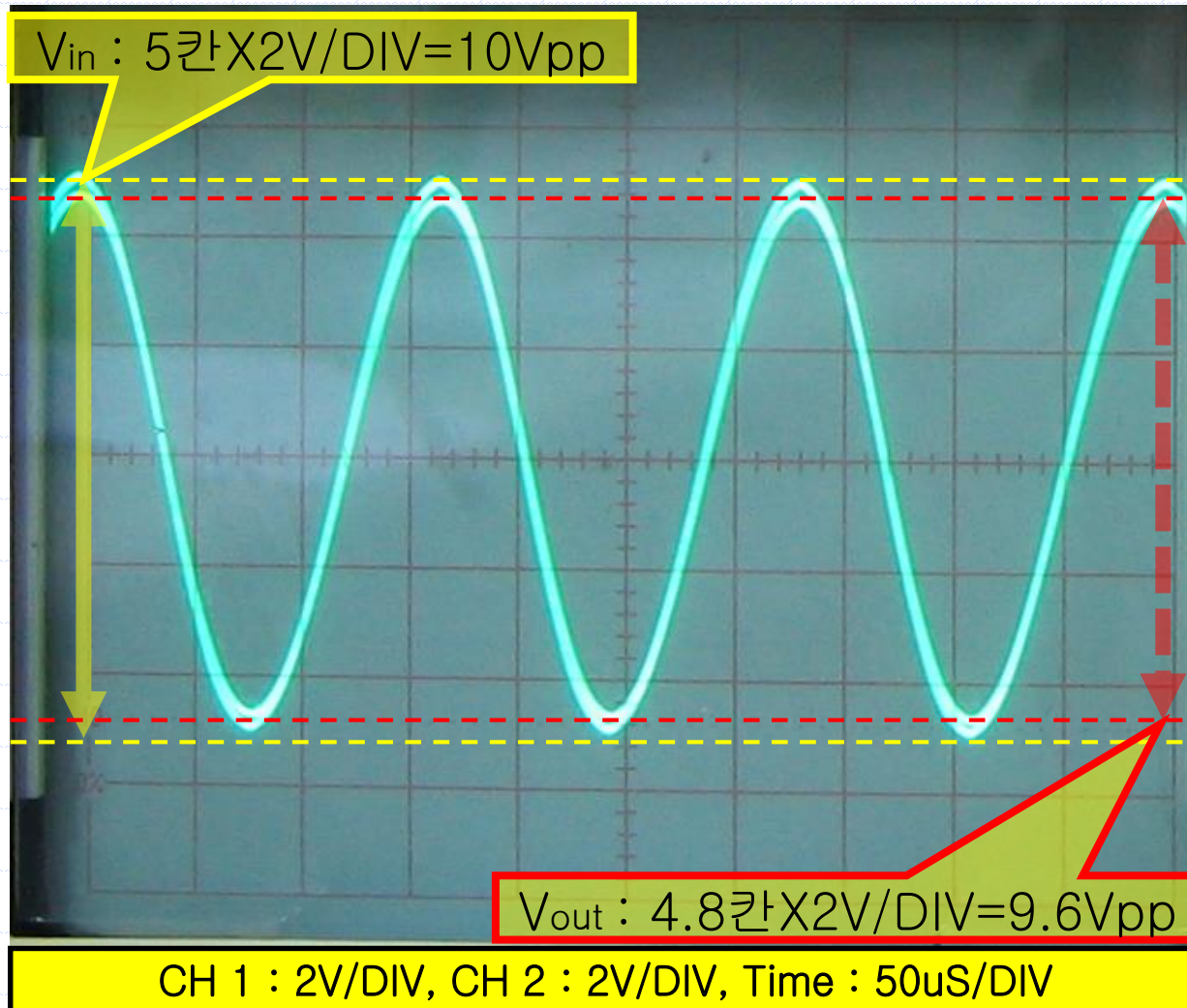

# 14-4. 주파수에 따른 전압

✓ 주파수 : 7kHz

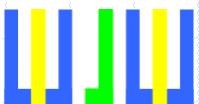
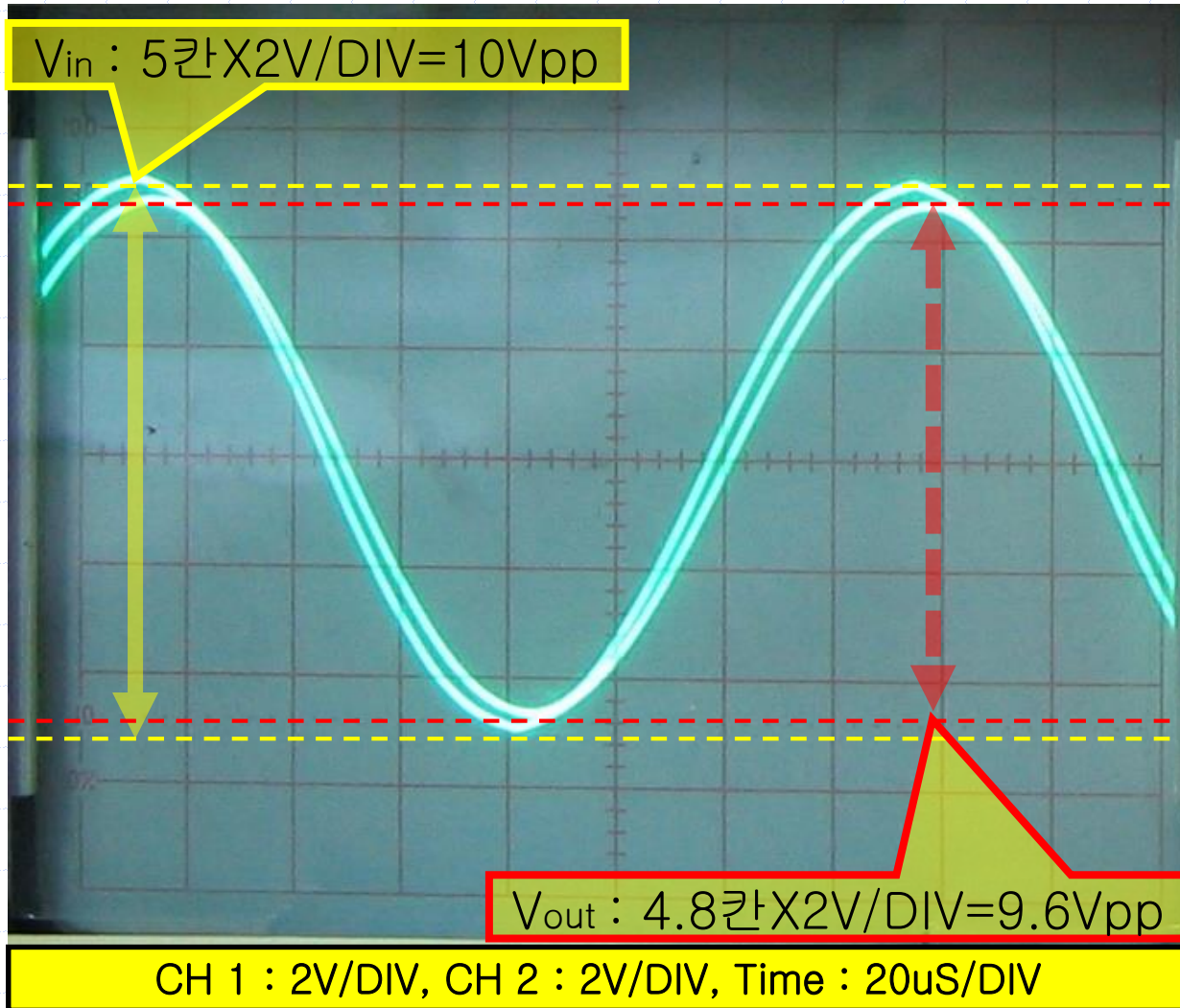



# 14-4. 주파수에 따른 전압

✓ 주파수 : 8kHz

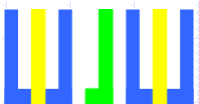
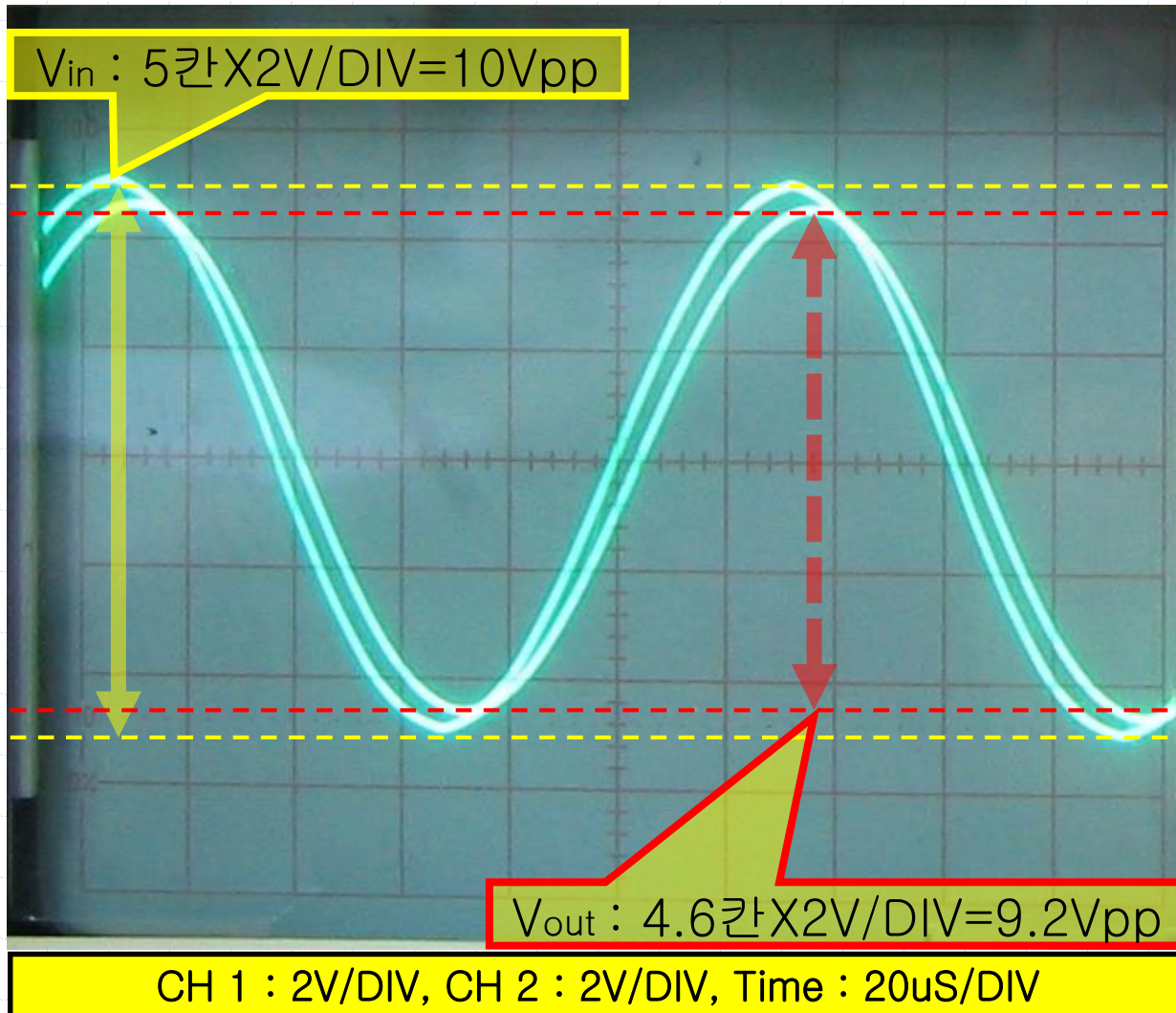

# 14-4. 주파수에 따른 전압

✓ 주파수 : 9kHz

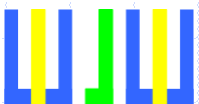
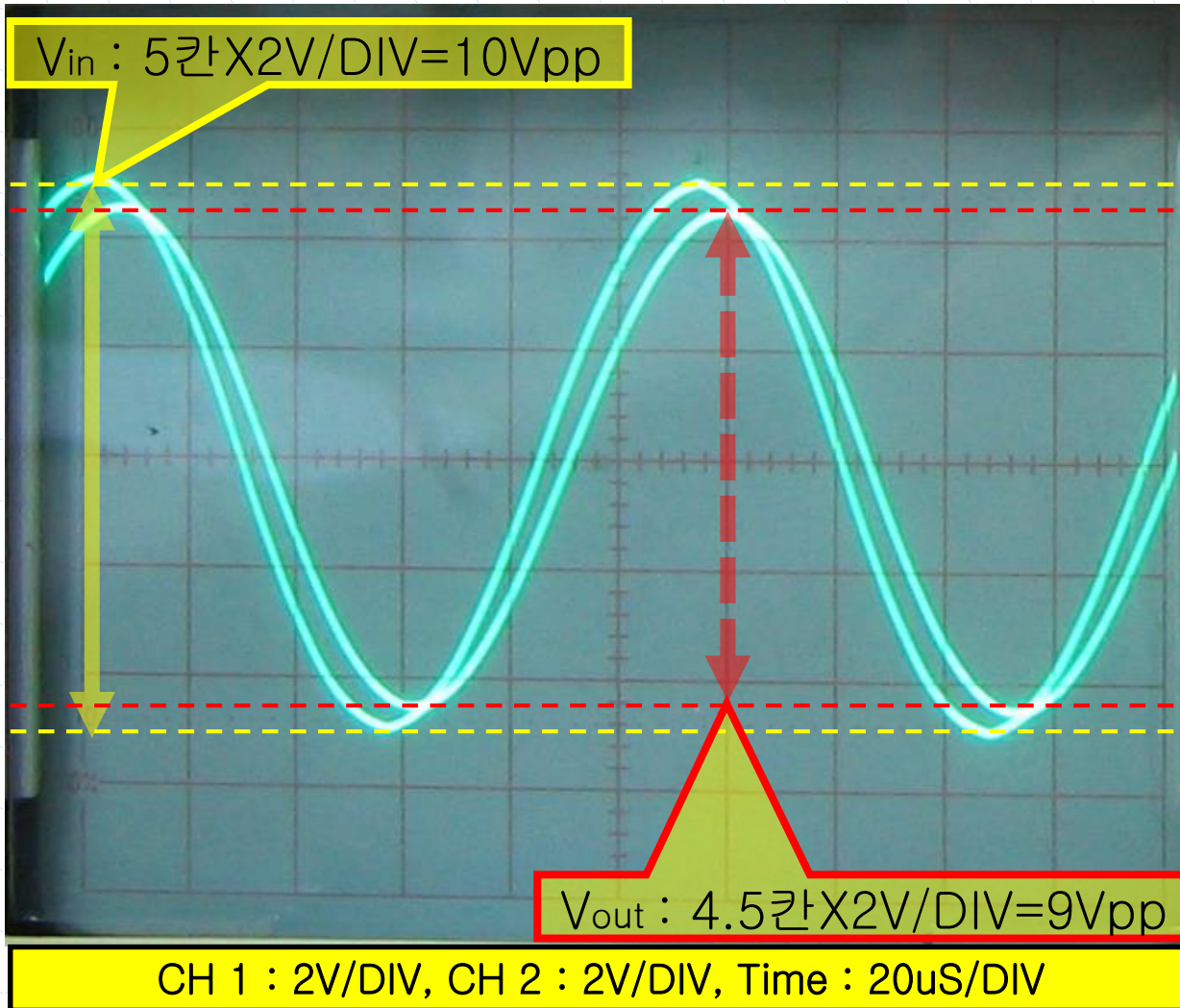

# 14-4. 주파수에 따른 전압

✓ 주파수 : 10kHz

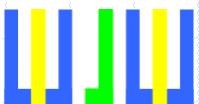
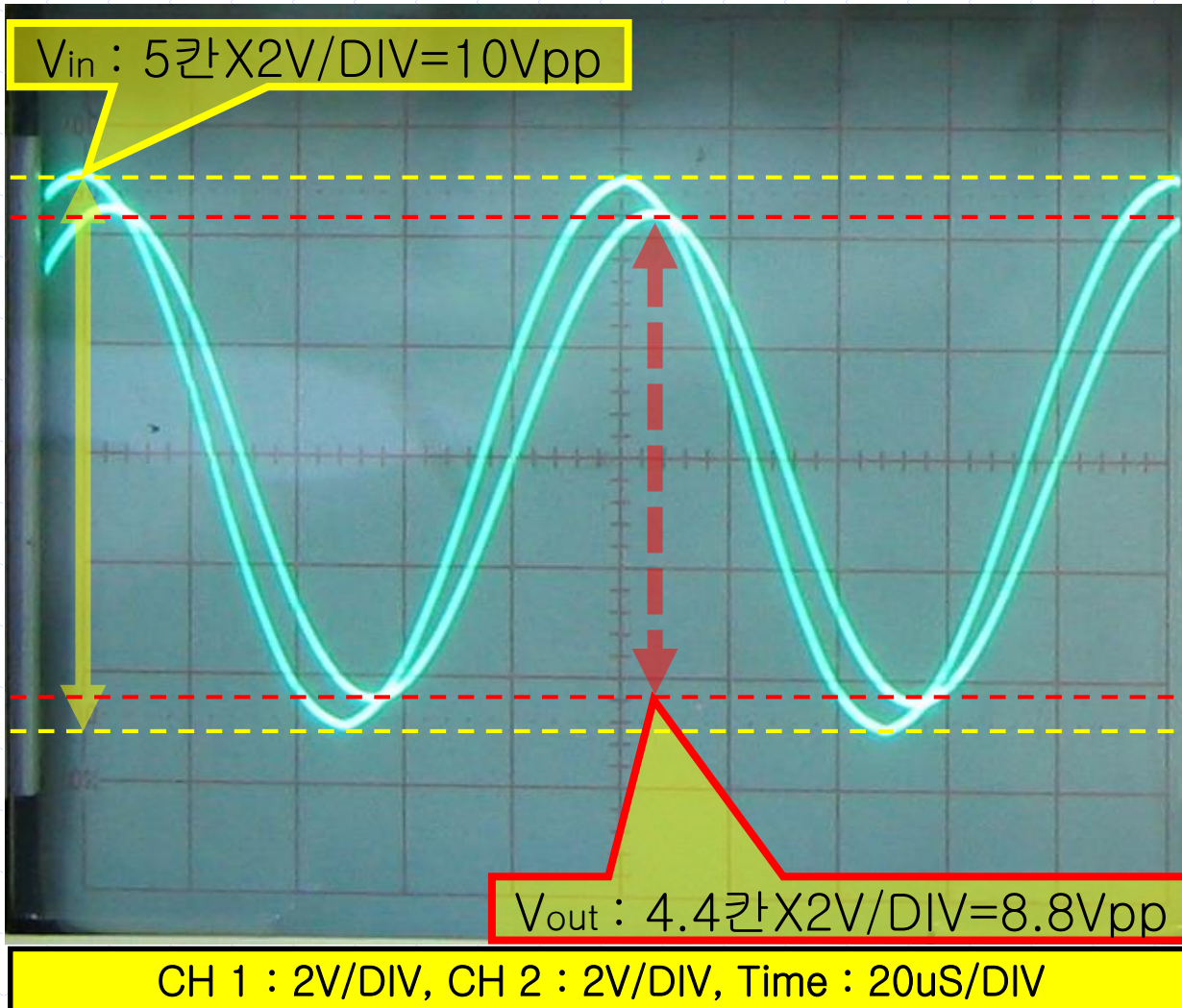



# 14-4. 주파수에 따른 전압

✓ 주파수 : 15kHz

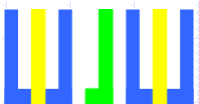
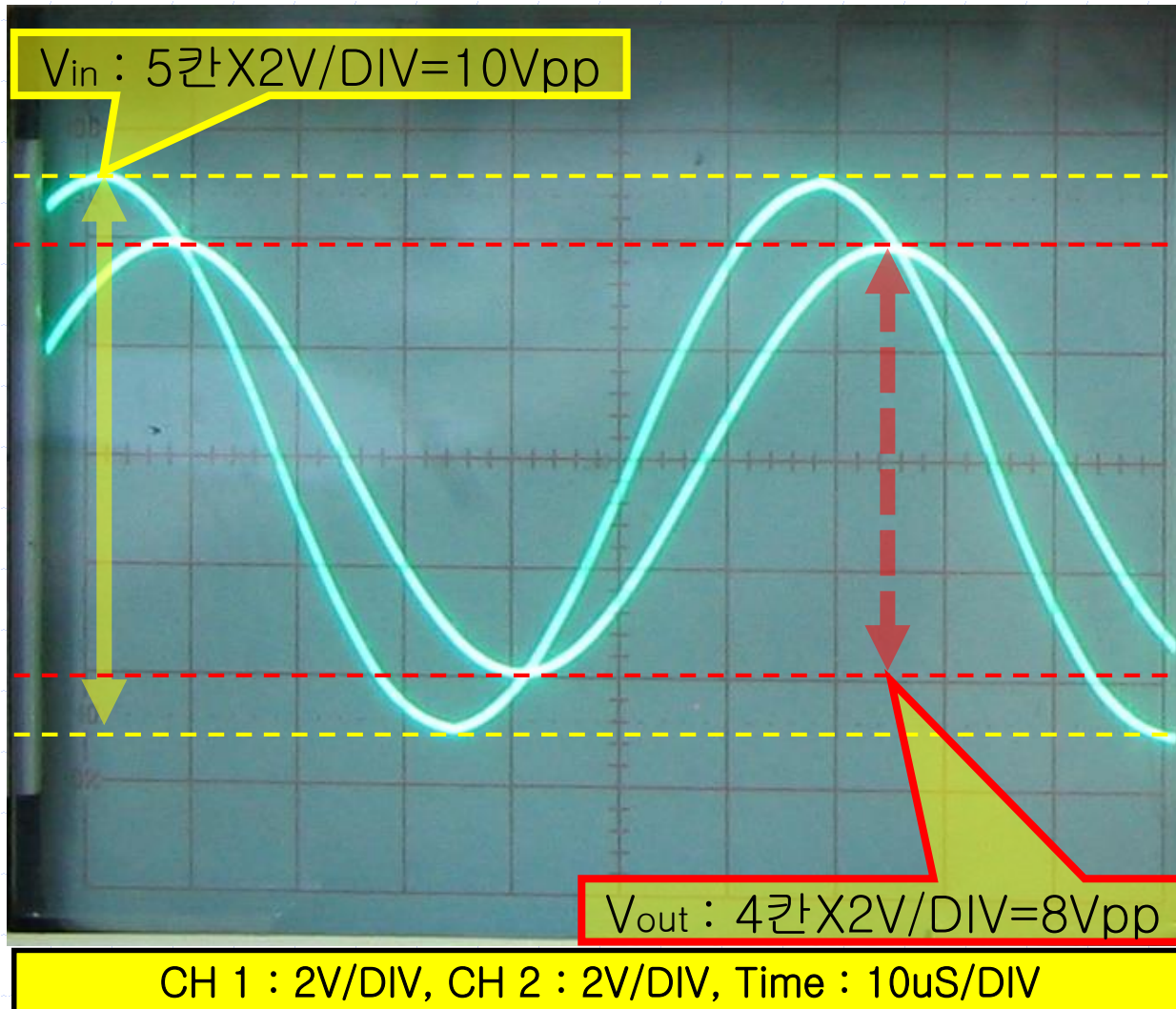

# 14-4. 주파수에 따른 전압

✓ 주파수 : 20kHz

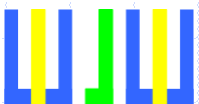
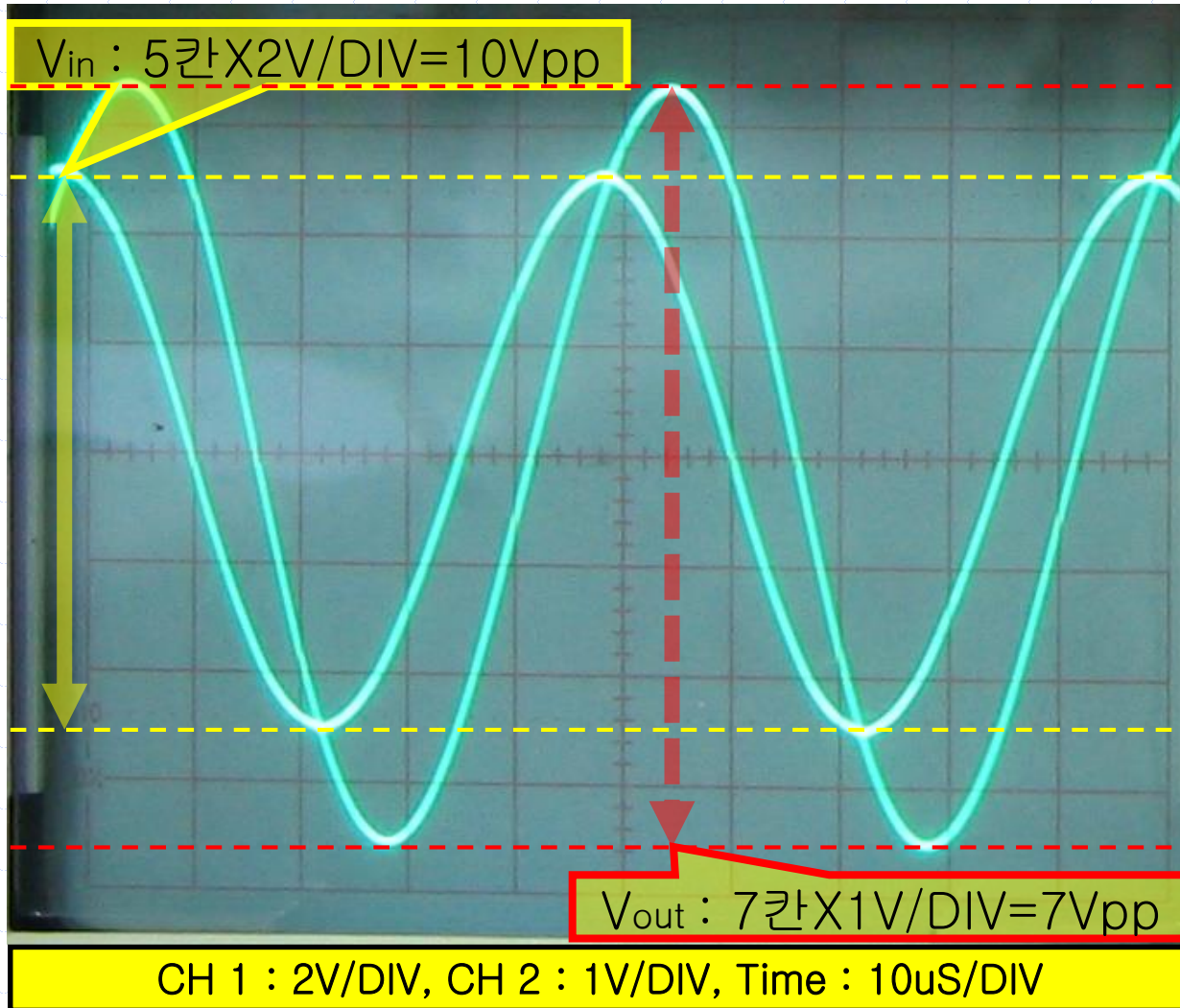



# 14-4. 주파수에 따른 전압

✓ 주파수 : 30kHz

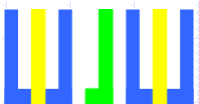
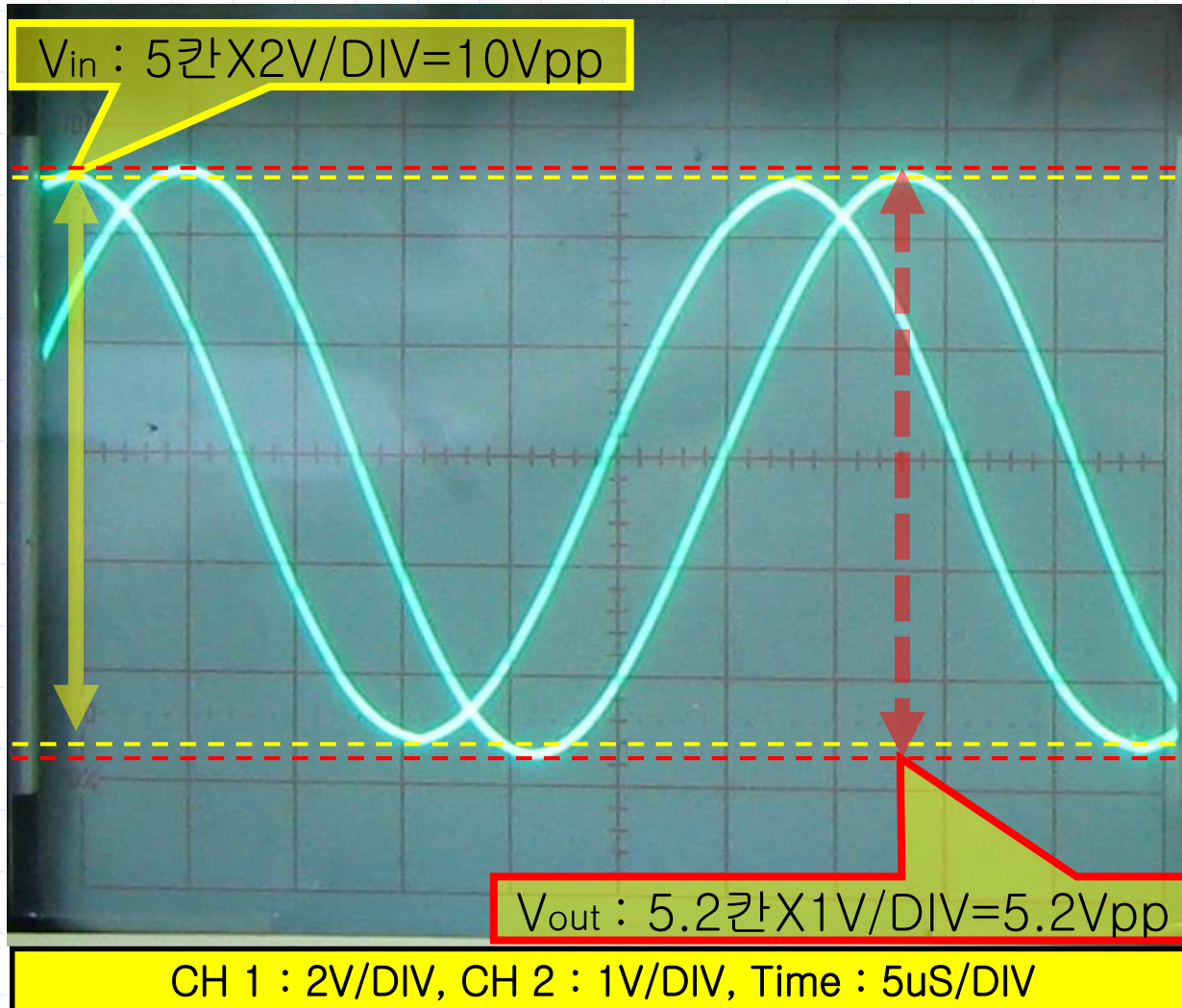

# 14-4. 주파수에 따른 전압

✓ 주파수 : 40kHz

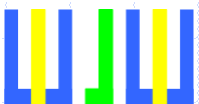
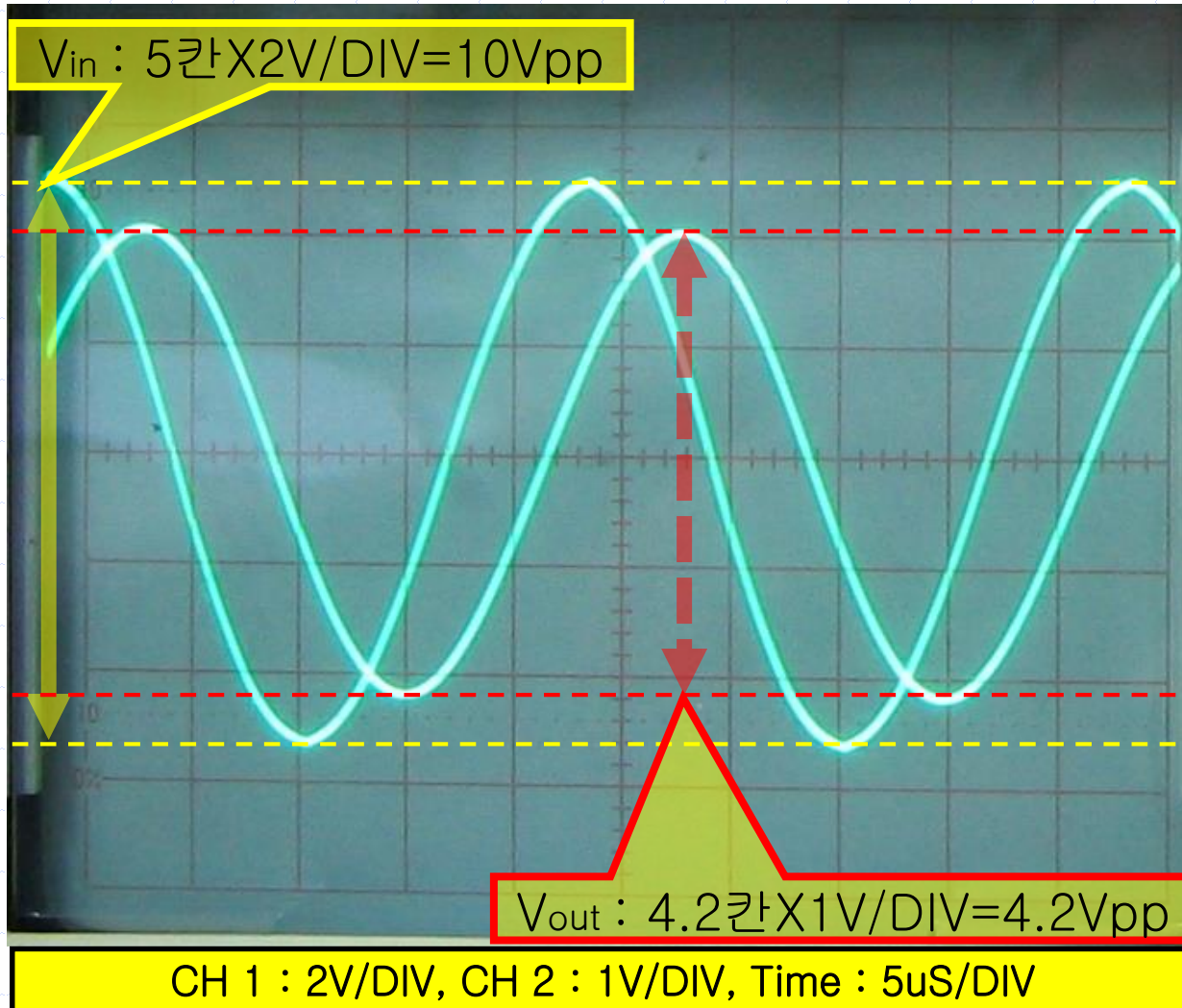

# 14-4. 주파수에 따른 전압

✓ 주파수 : 50kHz

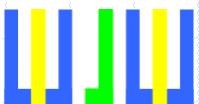
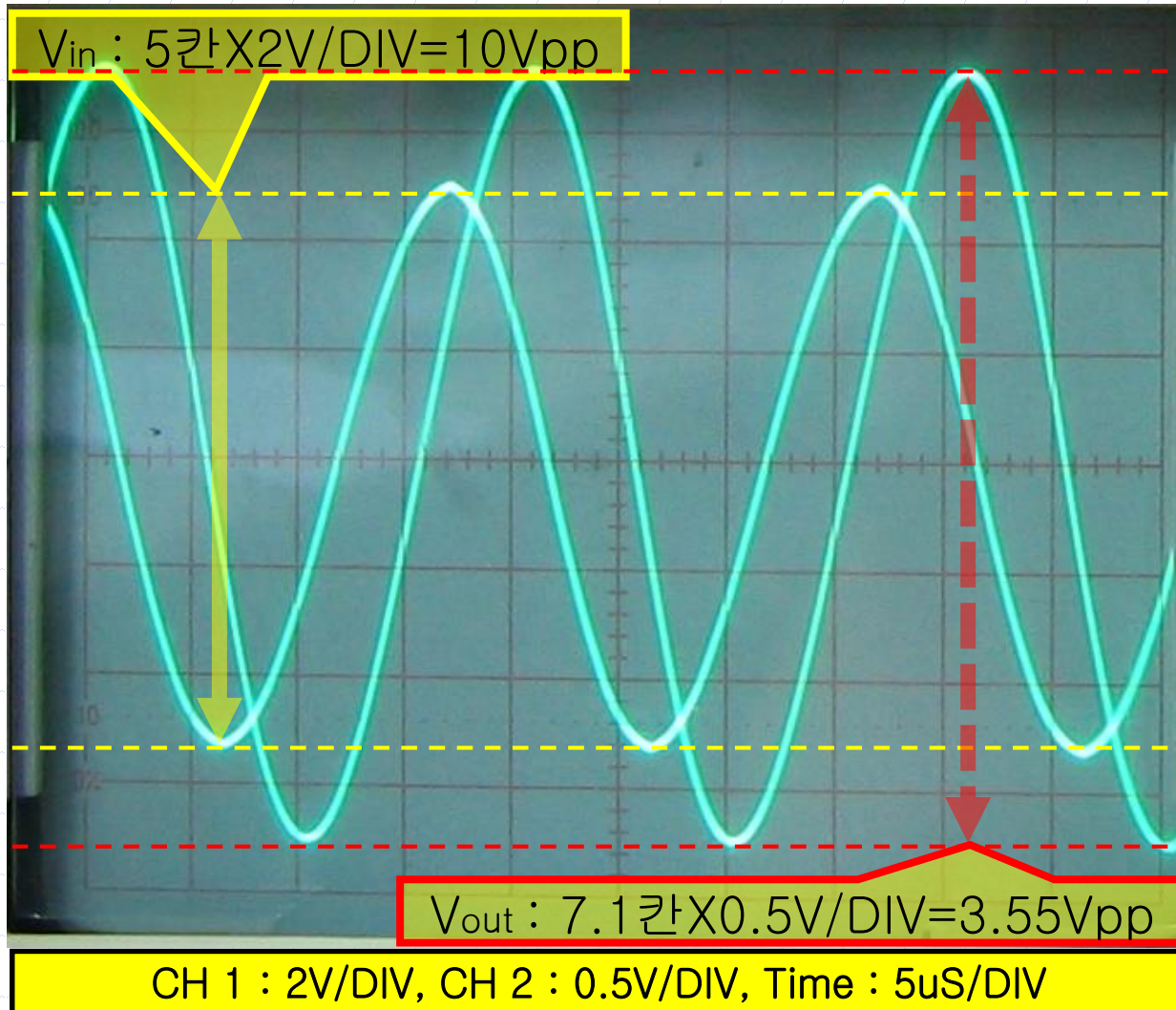

# 14-4. 주파수에 따른 전압

Frequency (Hz)	이론				실험			
	Vin (Vpp)	Vout (Vpp)	전압 이득	전압 이득 (dB)	Vin (Vpp)	Vout (Vpp)	전압 이득	전압 이득 (dB)
200	10	1.25	0.125	-18.06	10	1.26	0.126	-17.99
500	10	3.02	0.302	-10.40	10	2.9	0.29	-10.75
1,000	10	5.47	0.547	-5.24	10	5.2	0.52	-5.68
2,000	10	8.31	0.831	-1.61	10	7.5	0.75	-2.50
3,000	10	9.46	0.946	-0.48	10	8.6	0.86	-1.31
4,000	10	9.89	0.989	-0.10	10	9	0.9	-0.92
5,000	10	9.99	0.999	-0.01	10	9.6	0.96	-0.35
6,000	10	9.94	0.994	-0.05	10	9.6	0.96	-0.35
7,000	10	9.78	0.978	-0.19	10	9.6	0.96	-0.35
8,000	10	9.57	0.957	-0.38	10	9.2	0.92	-0.72
9,000	10	9.32	0.932	-0.61	10	9	0.9	-0.92
10,000	10	9.05	0.905	-0.87	10	8.8	0.88	-1.11
15,000	10	7.67	0.767	-2.30	10	8	0.8	-1.94
20,000	10	6.47	0.647	-3.78	10	7	0.7	-3.10
30,000	10	4.79	0.479	-6.39	10	5.2	0.52	-5.68
40,000	10	3.75	0.375	-8.52	10	4.2	0.42	-7.54
50,000	10	3.06	0.306	-10.29	10	3.55	0.355	-9.00



# 14-4. 주파수에 따른 전압

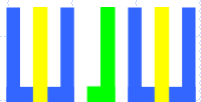
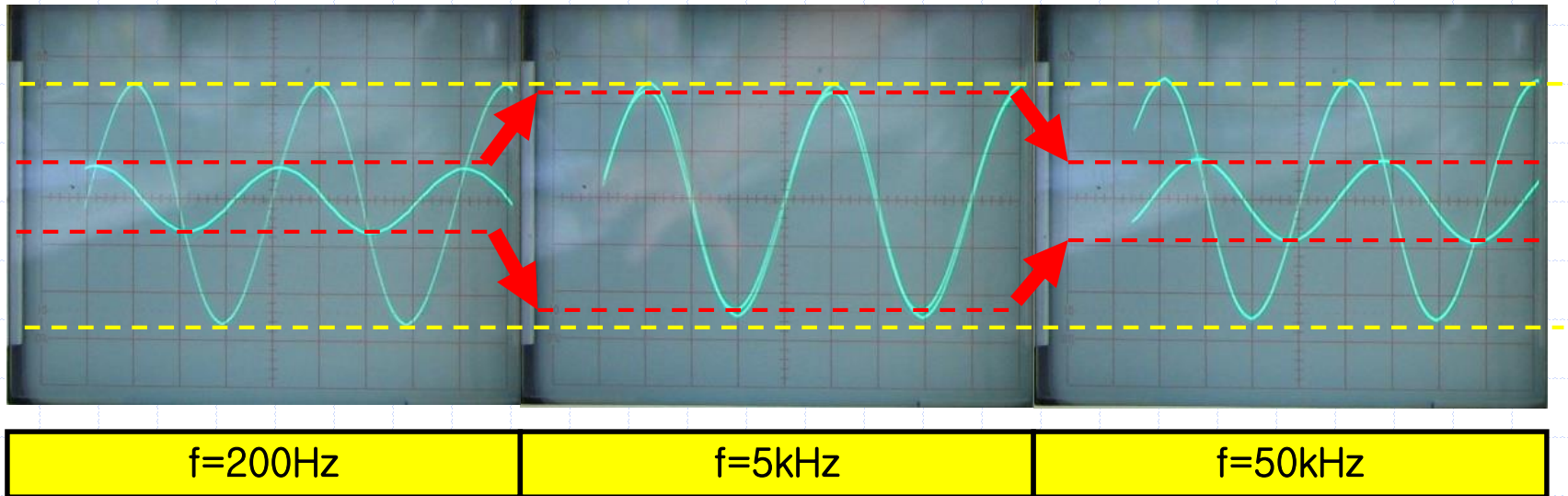

# 14-4. 주파수에 따른 전압

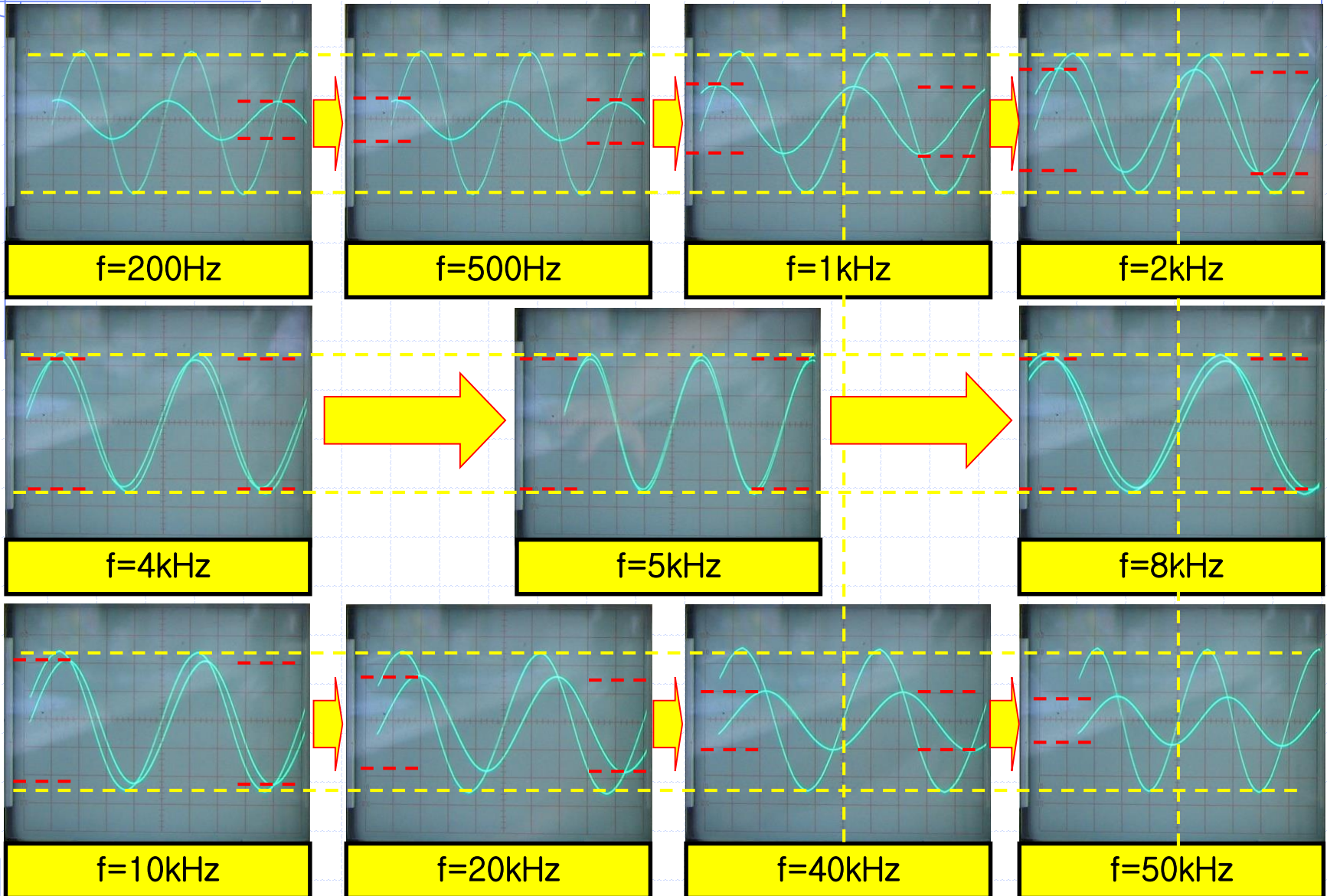

# 14-5. 공진 주파수

전압 이득

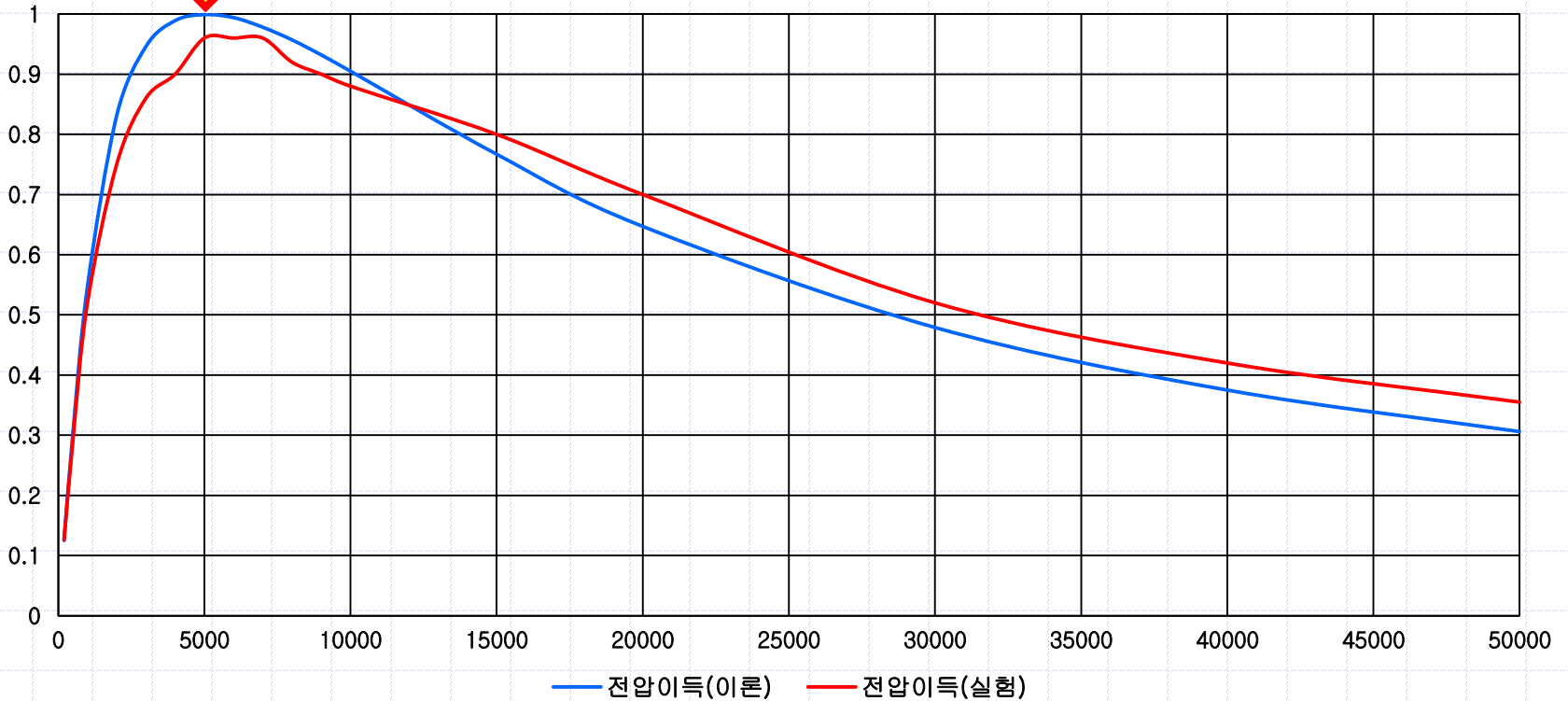

$$f_r = \frac{1}{2\pi\sqrt{LC}} = \frac{1}{2\pi\sqrt{10mH \times 0.1\mu F}} = 5032.9Hz$$

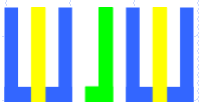

# 14-6. 대역폭 측정

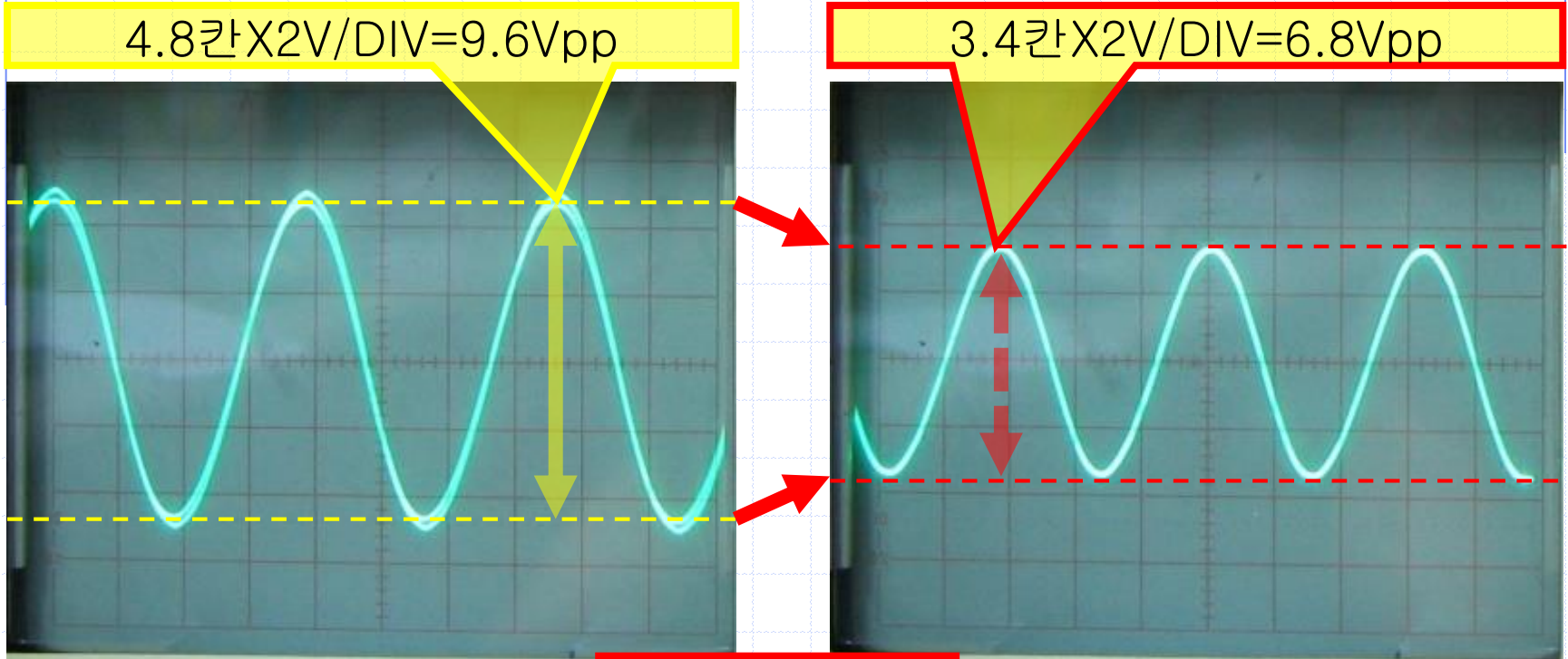

CH 1 : 2V/DIV, CH 2 : 0.5V/DIV, Time : 5uS/DIV

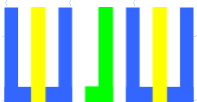



# 14-6. 대역폭 측정

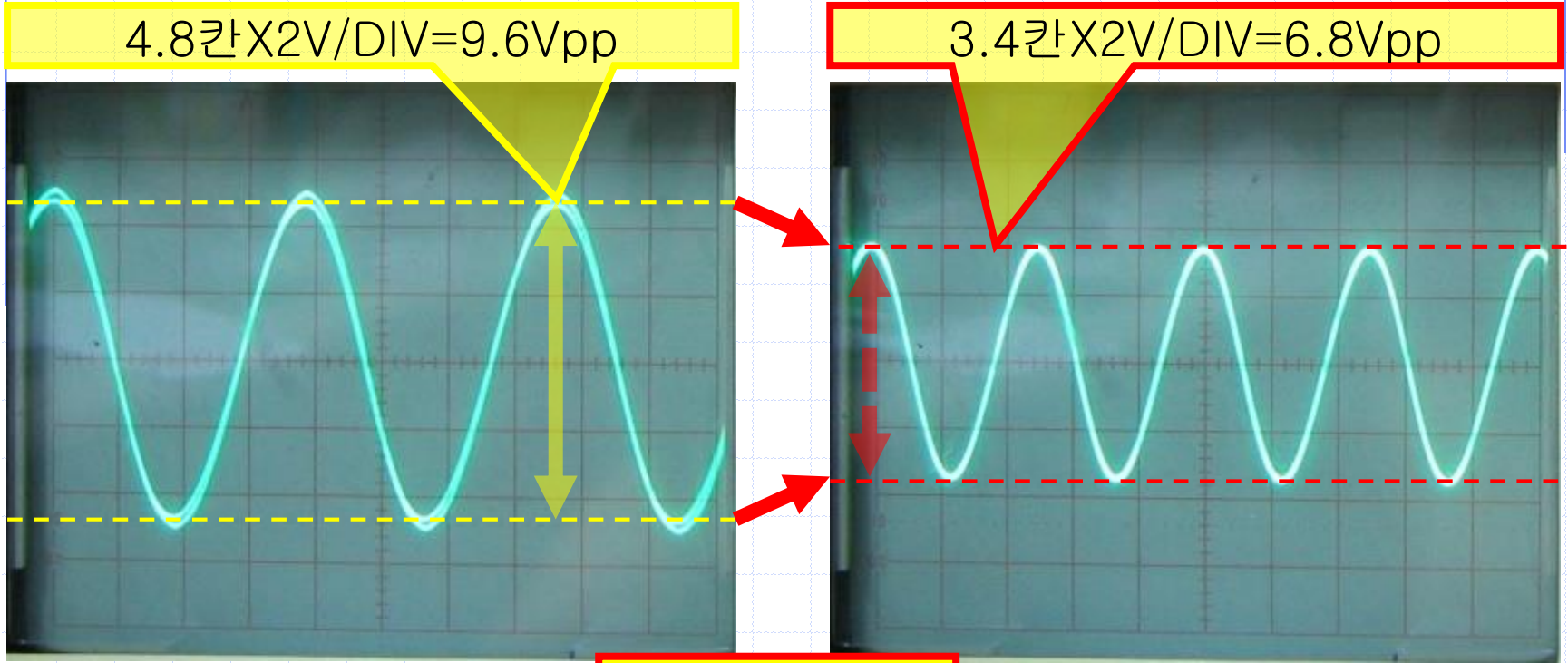

공진주파수 : 5.032kHz

0.707 (3dB)

상한주파수 : 20.05kHz

CH 1 : 2V/DIV, CH 2 : 0.5V/DIV, Time : 5uS/DIV

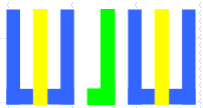

# 14-7. 주파수에 따른 위상 변화

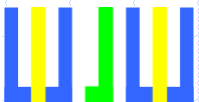
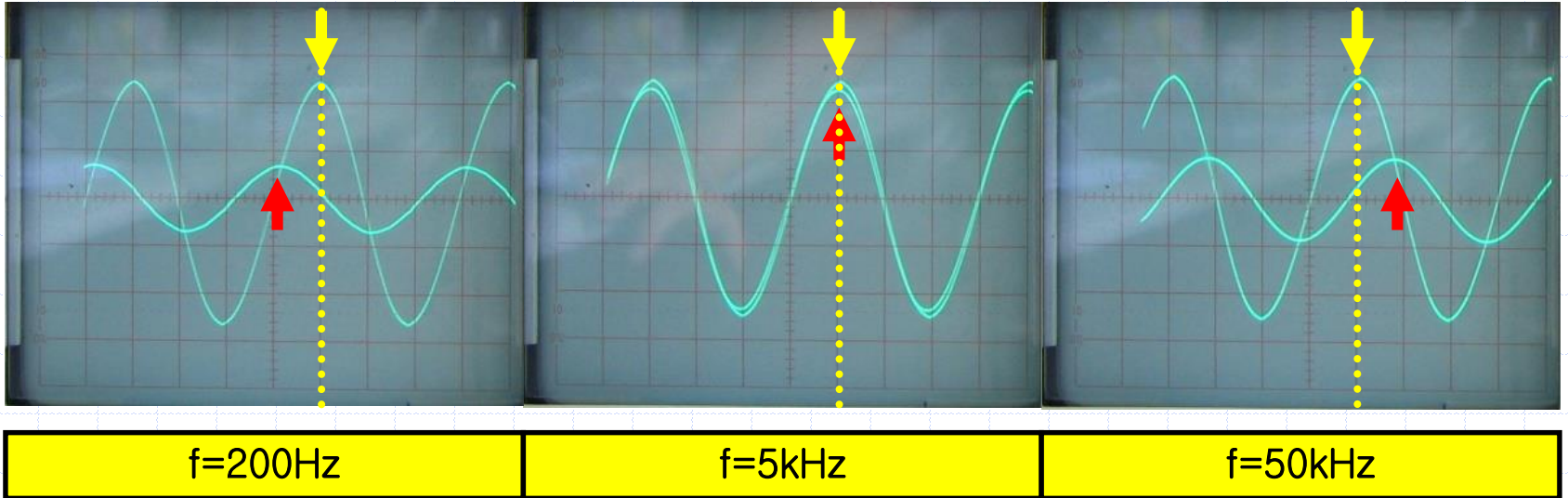

# 14-7. 주파수에 따른 위상 변화

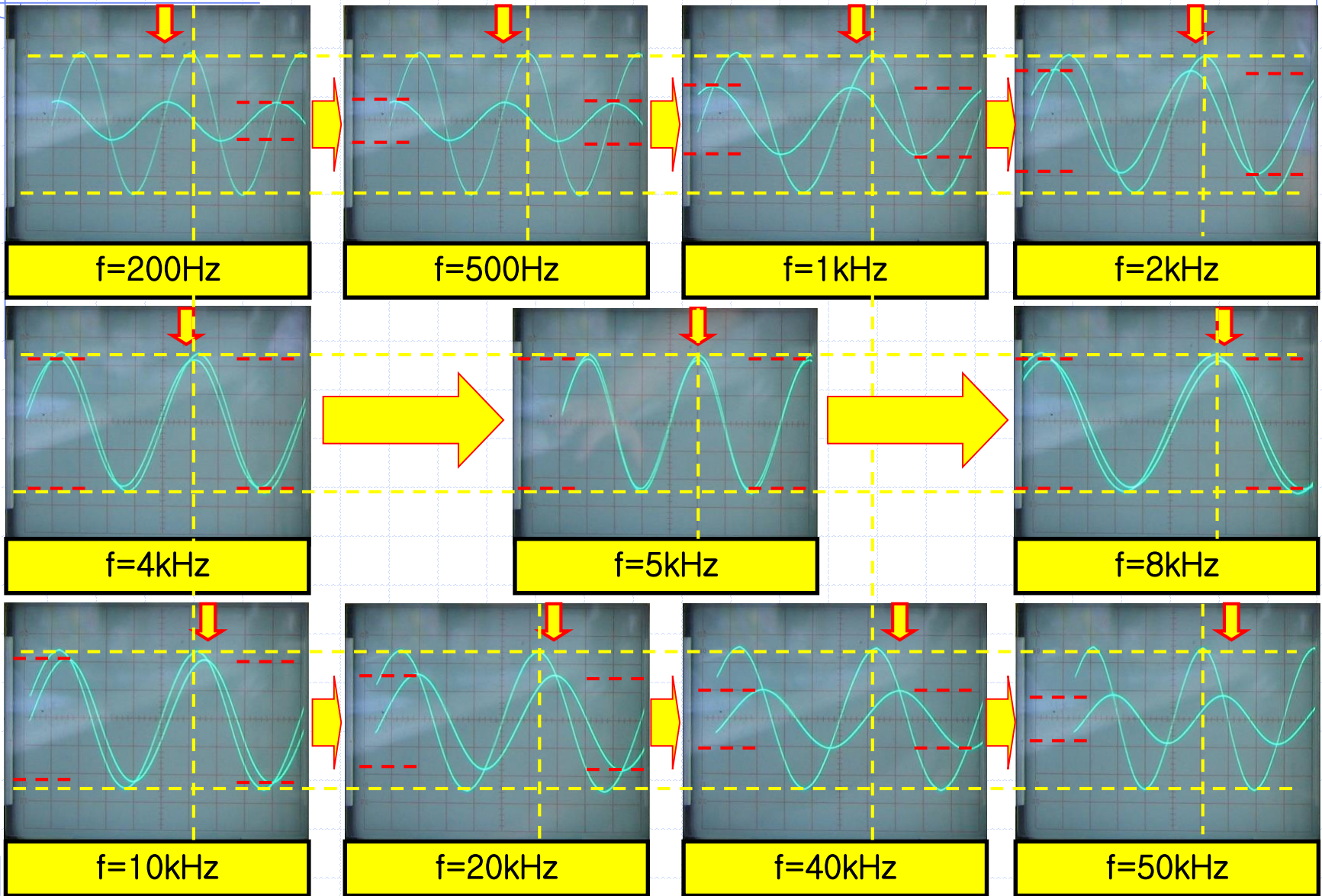

# 14-7. 주파수에 따른 위상 변화

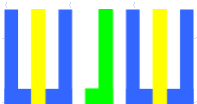
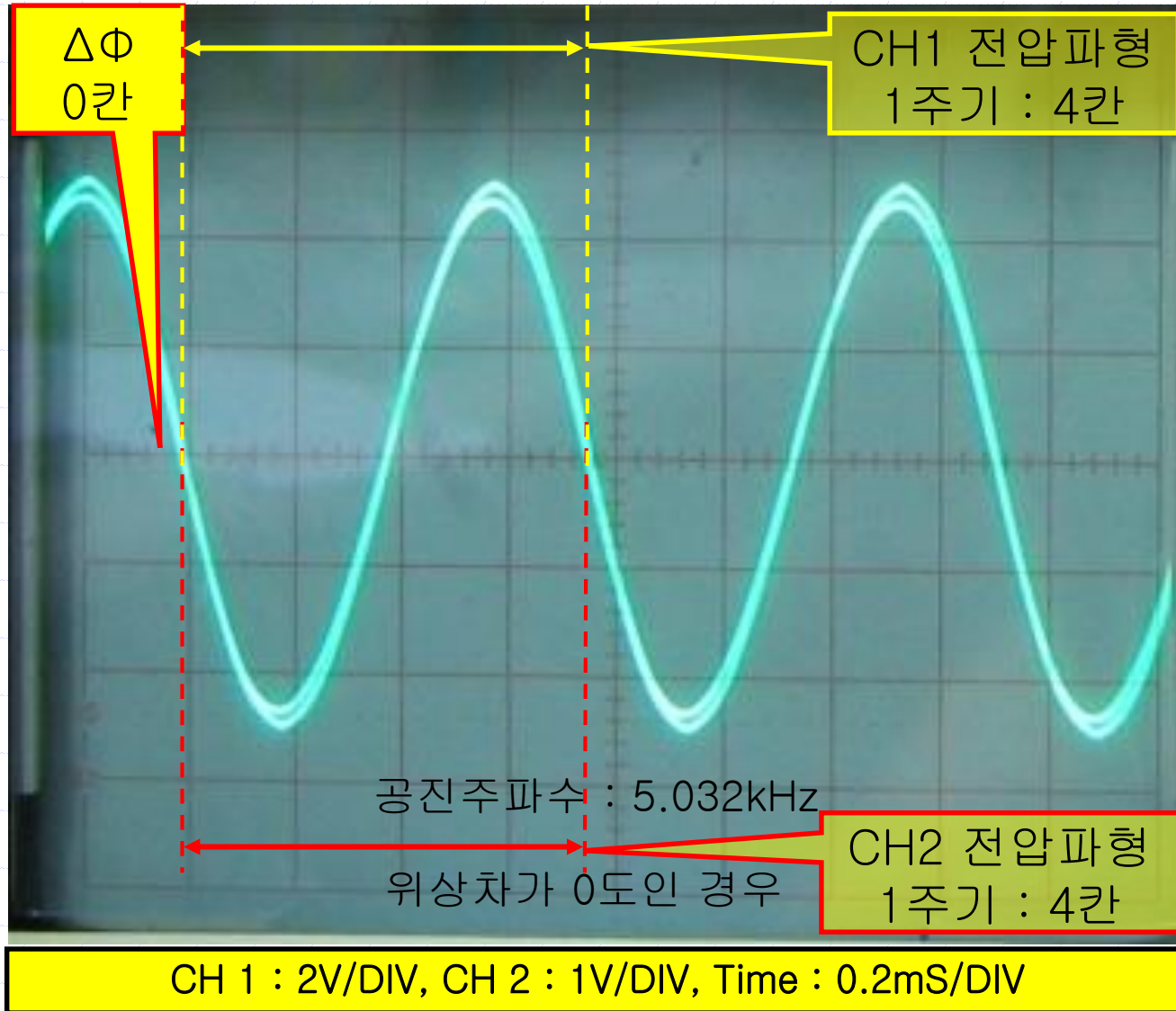



# 14-7. 주파수에 따른 위상 변화

✓ 위상차를 측정하라. (주파수 : 1kHz)

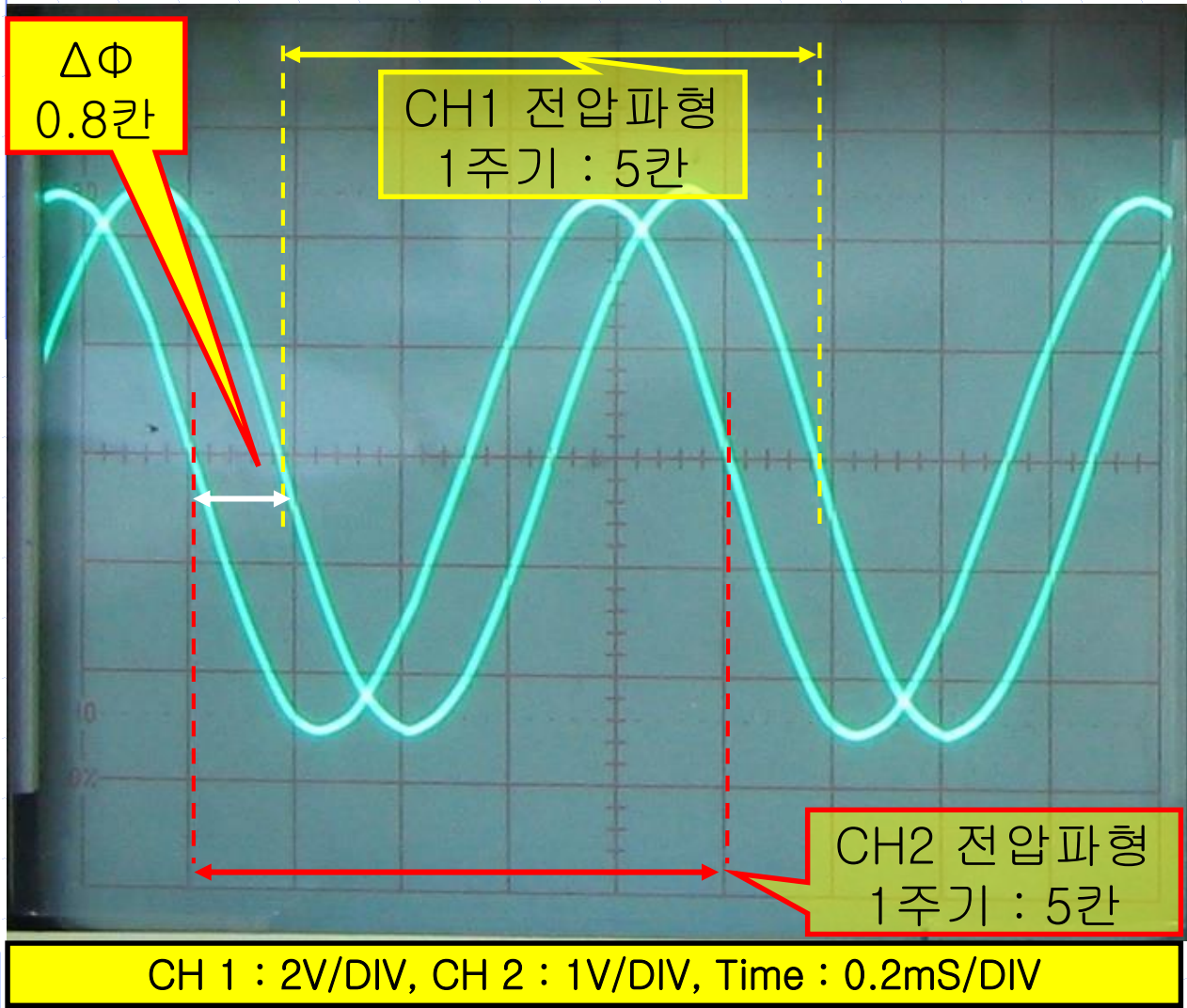

$$1T = 5\text{칸} \times 0.2\text{mSec} = 1\text{mSec}$$

$$\Delta t = 0.8\text{칸} \times 0.2\text{mSec} = 0.16\text{mSec}$$

$$1\text{mSec} : 0.16\text{mSec} = 360^\circ : \Delta\theta$$

$$\Delta\theta = -57.6^\circ$$

# 14-7. 주파수에 따른 위상 변화

✓ 위상차를 측정하라. (주파수 : 4kHz)

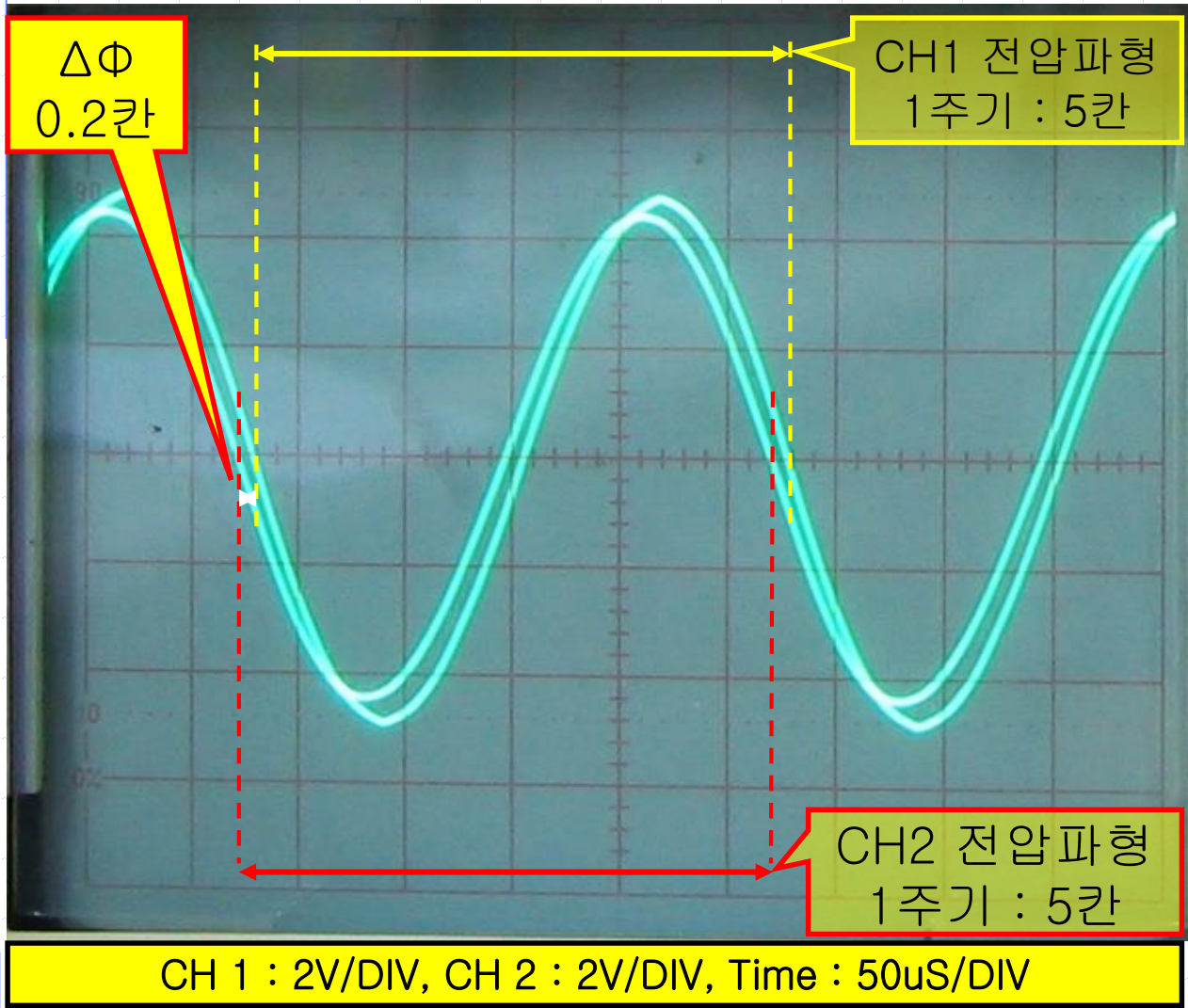

$$1T = 5\text{칸} \times 50\mu\text{Sec} = 250\mu\text{Sec}$$

$$\Delta t = 0.2\text{칸} \times 50\mu\text{Sec} = 10\mu\text{Sec}$$

$$250\mu\text{Sec} : 10\mu\text{Sec} = 360^\circ : \Delta\theta$$

$$\Delta\theta = -14.4^\circ$$

# 14-7. 주파수에 따른 위상 변화

✓ 위상차를 측정하라. (주파수 : 5kHz)

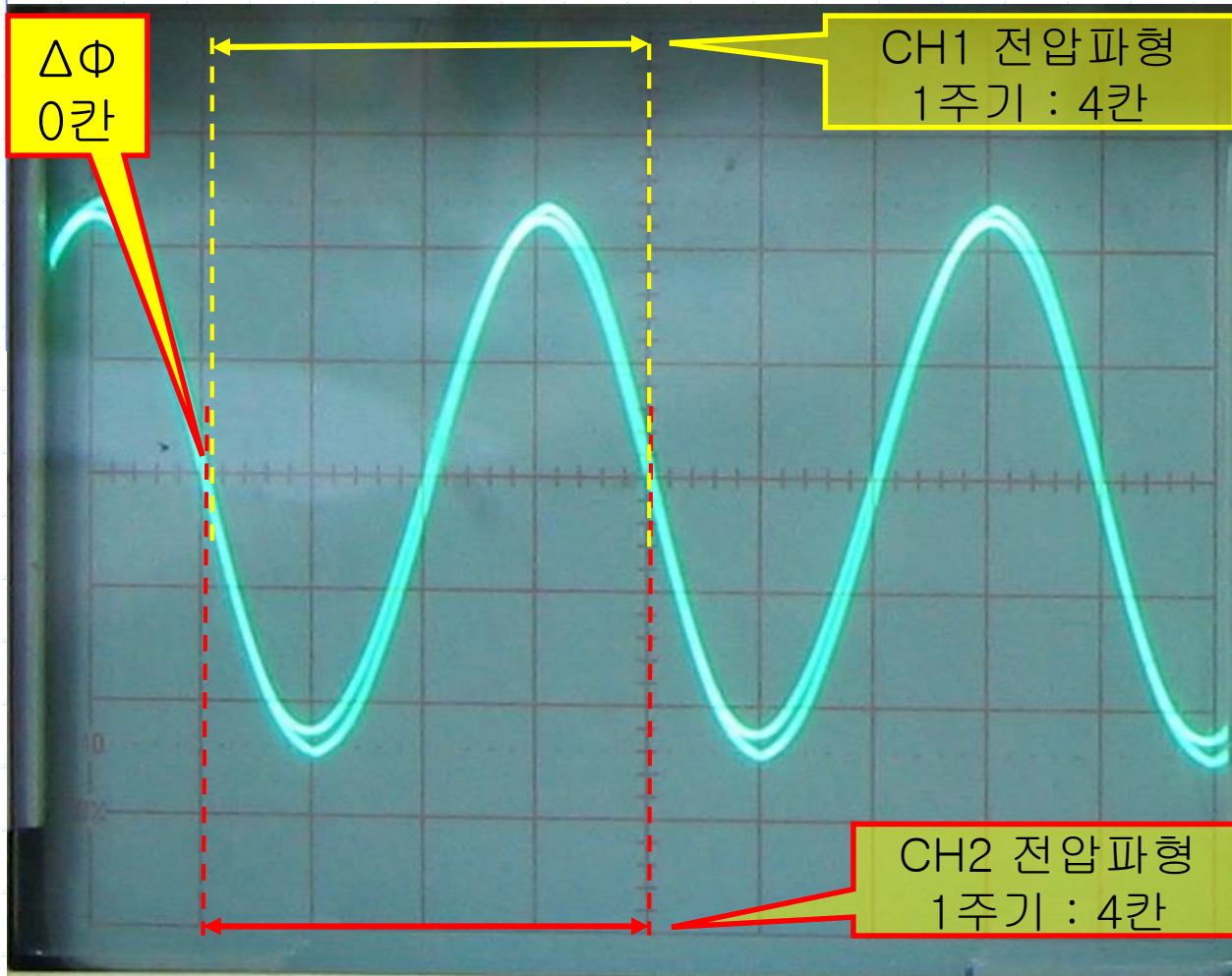

$$1T = 4\text{칸} \times 50\mu\text{Sec} = 200\mu\text{Sec}$$

$$\Delta t = 0\text{칸} \times 50\mu\text{Sec} = 0\mu\text{Sec}$$

$$200\mu\text{Sec} : 0\mu\text{Sec} = 360^\circ : \Delta\theta$$

$$\Delta\theta = 0^\circ$$

CH 1 : 2V/DIV, CH 2 : 2V/DIV, Time : 50uS/DIV



# 14-7. 주파수에 따른 위상 변화

✓ 위상차를 측정하라. (주파수 : 10kHz)

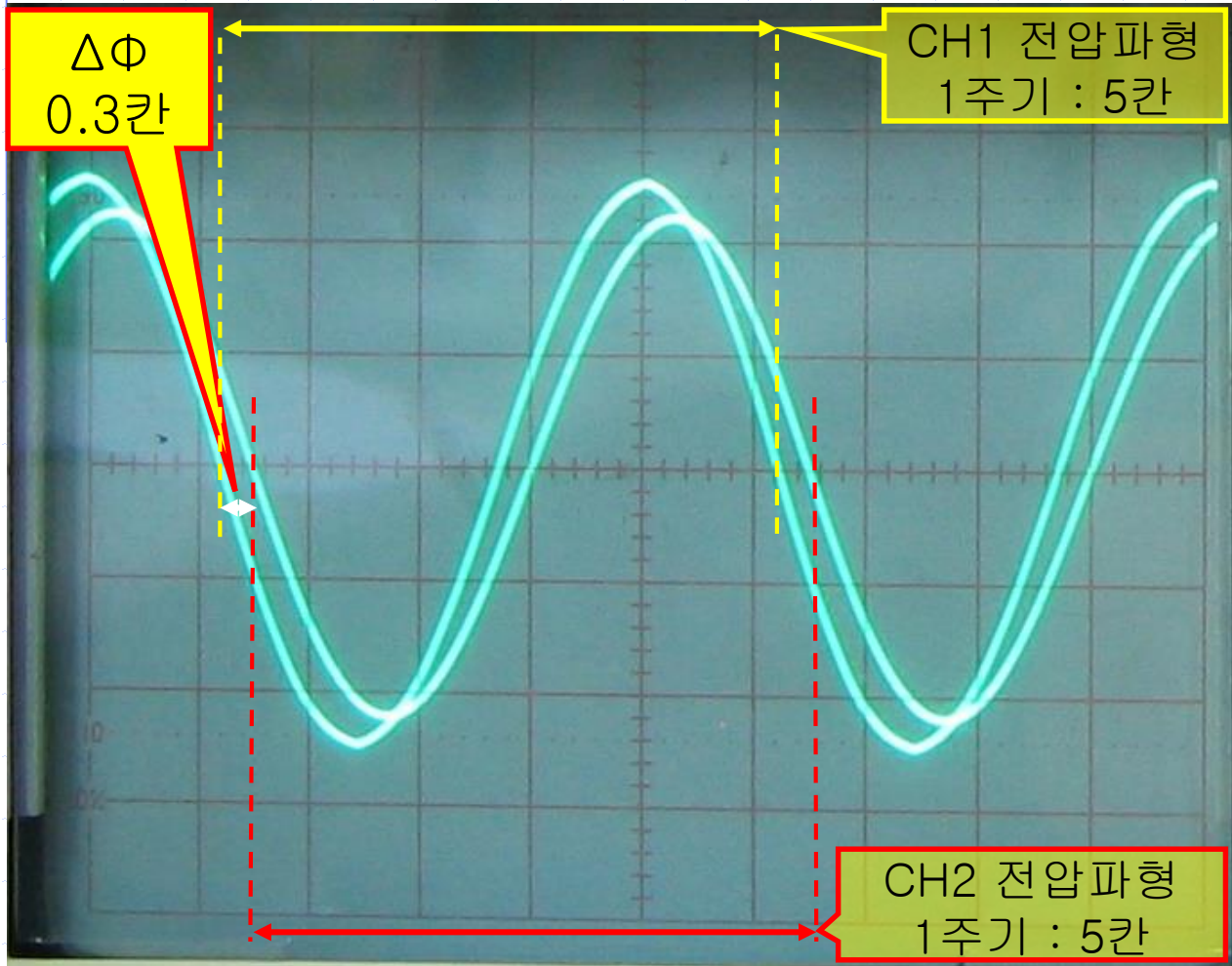

$$1T = 5\text{칸} \times 20\mu\text{Sec} = 100\mu\text{Sec}$$

$$\Delta t = 0.3\text{칸} \times 20\mu\text{Sec} = 6\mu\text{Sec}$$

$$100\mu\text{Sec} : 6\mu\text{Sec} = 360^\circ : \Delta\theta$$

$$\Delta\theta = 21.6^\circ$$

CH 1 : 2V/DIV, CH 2 : 2V/DIV, Time : 20uS/DIV



# 14-7. 주파수에 따른 위상 변화

✓ 위상차를 측정하라. (주파수 : 20kHz)

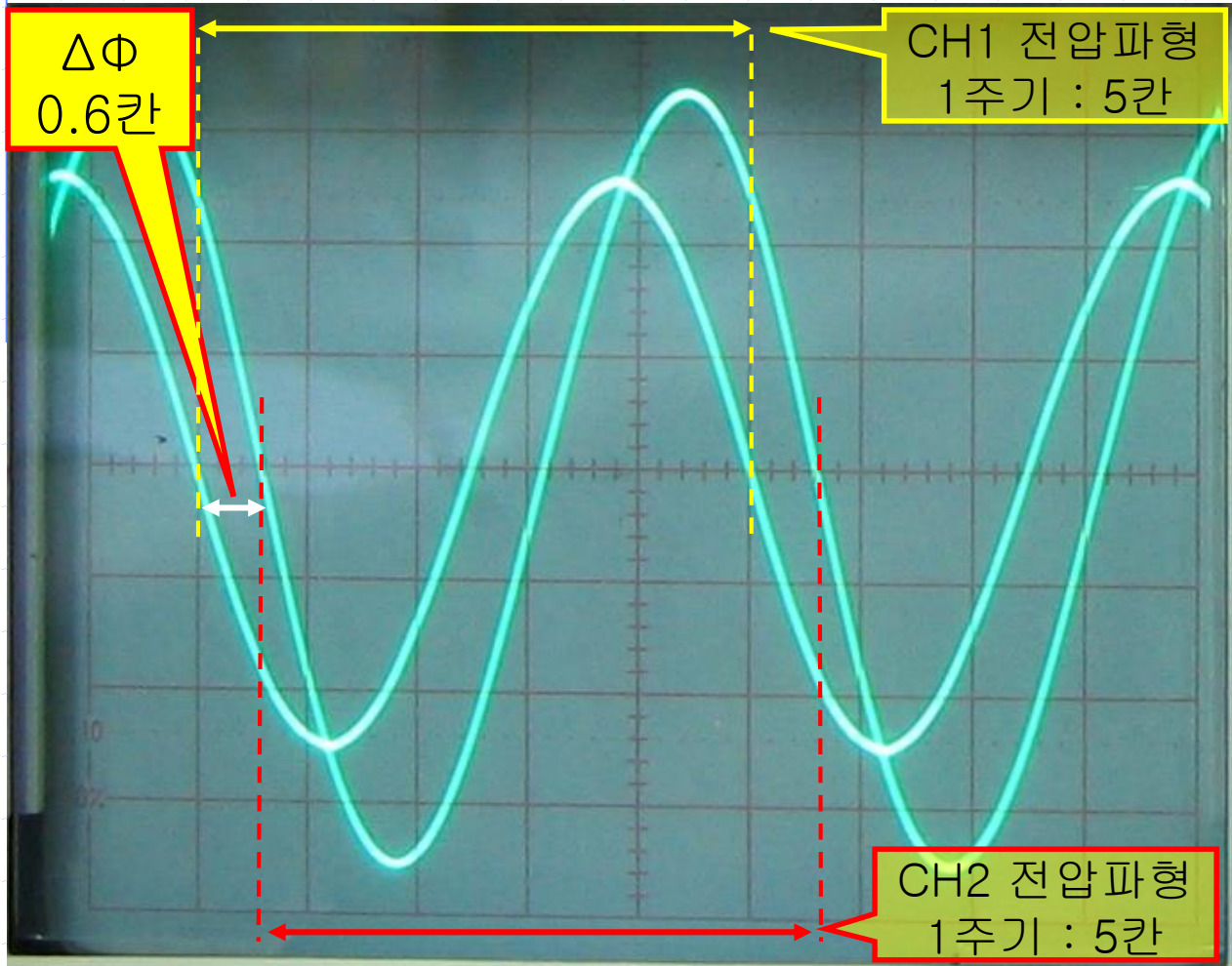

$$1T = 5\text{칸} \times 10\mu\text{Sec} = 50\mu\text{Sec}$$

$$\Delta t = 0.6\text{칸} \times 10\mu\text{Sec} = 6\mu\text{Sec}$$

$$50\mu\text{Sec} : 6\mu\text{Sec} = 360^\circ : \Delta\theta$$

$$\Delta\theta = 43.2^\circ$$

CH 1 : 2V/DIV, CH 2 : 1V/DIV, Time : 10uS/DIV

# 14-7. 주파수에 따른 위상 변화

위상차 (도)

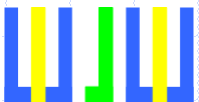
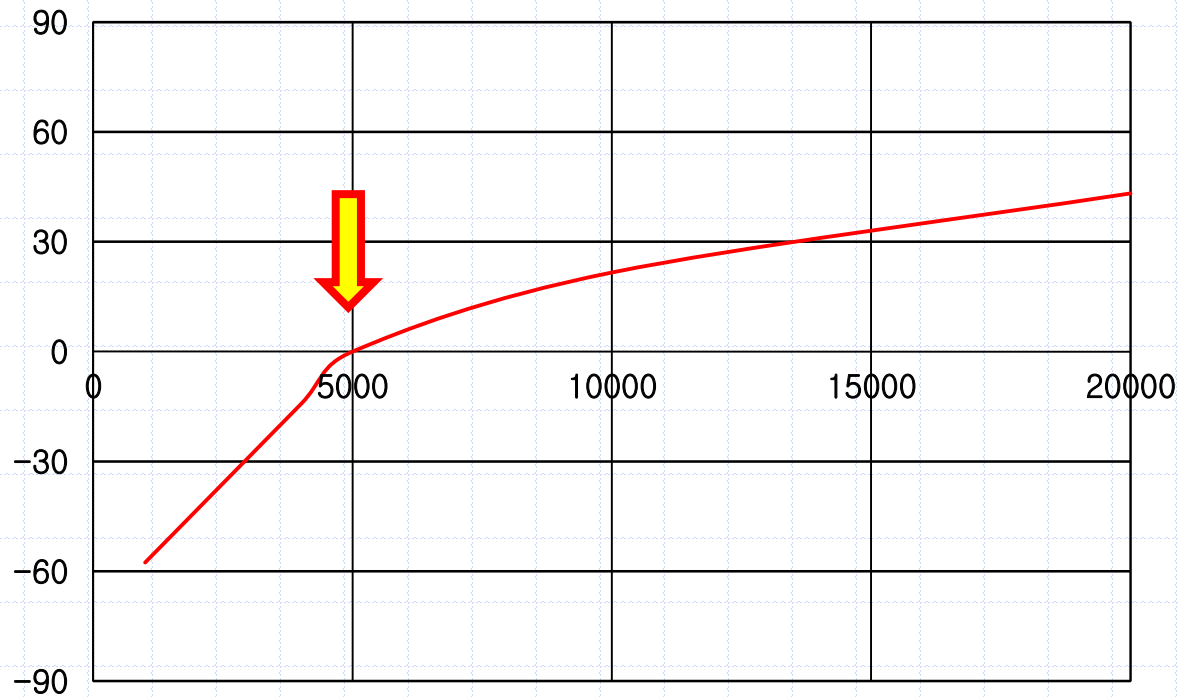

## 14-8. 주파수에 따른 전류 및 임피던스

- 다음과 같이 회로를 연결하고, 신호 발생기를 조절하여 주파수 500Hz, 10Vpp 의 정현파가 나오도록 한다.

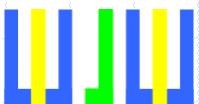
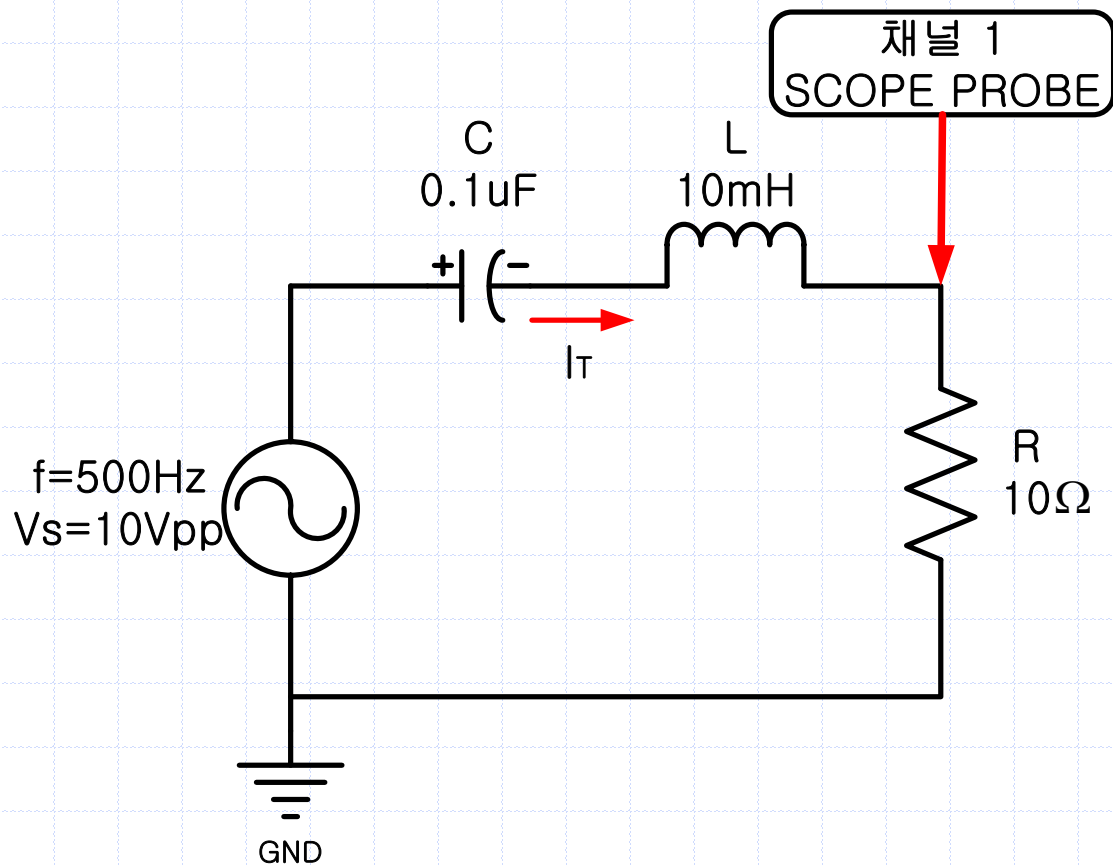

## 14-8. 주파수에 따른 전류 및 임피던스

- ✓ 다음과 같이 회로를 연결하고, 신호 발생기를 조절하여 주파수 500Hz, 10Vpp 의 정현파가 나오도록 한다.

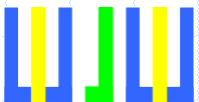
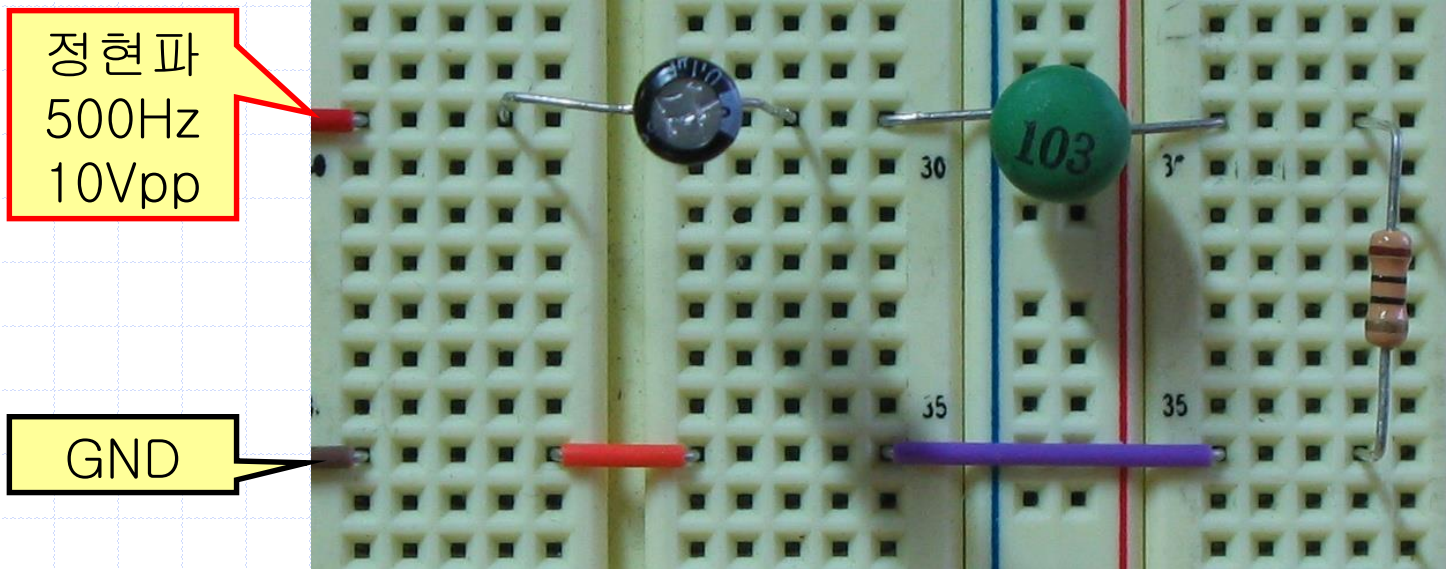



# 14-8. 주파수에 따른 전류 및 임피던스

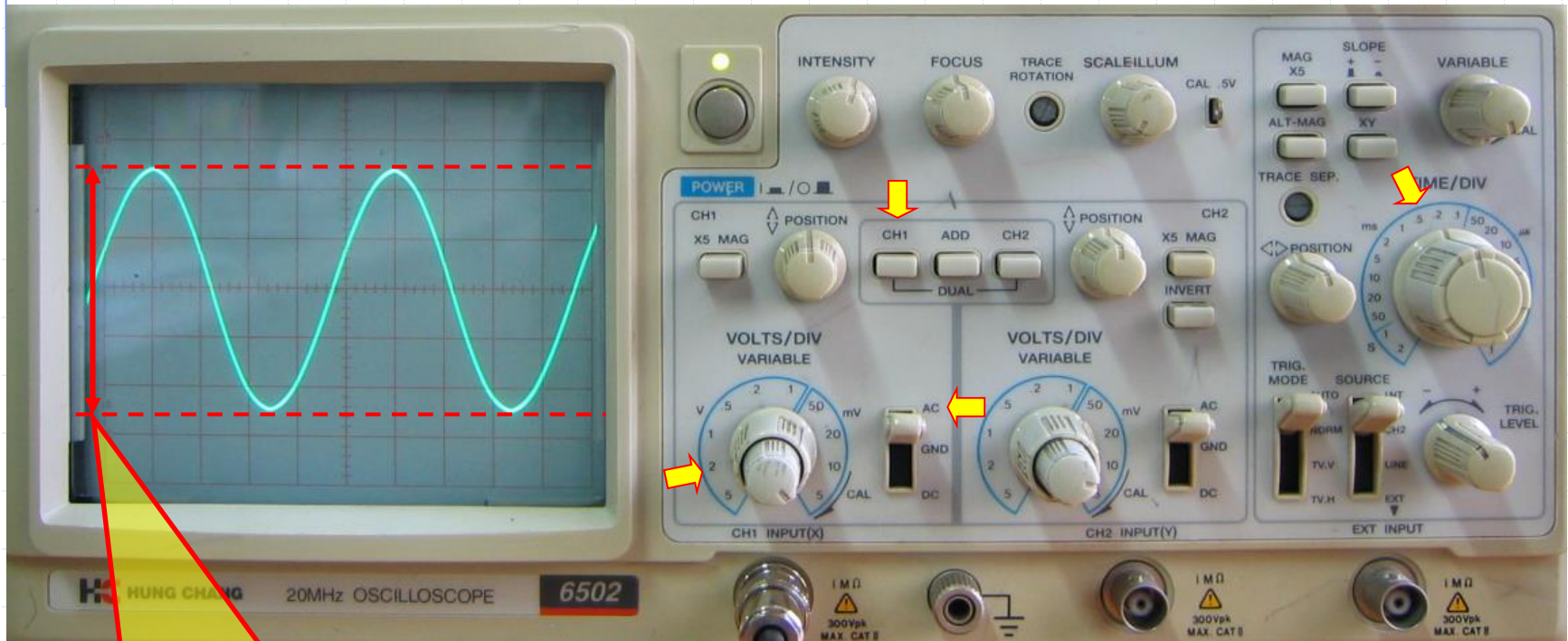

5칸 X 2V/DIV = 10Vpp

# 14-8. 주파수에 따른 전류 및 임피던스

- ✓ 오실로스코프의 CH 1 을 이용하여 저항 양단의 출력 전압 ( $V_{out}$ ) 을 측정한다.

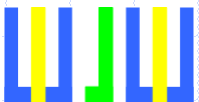
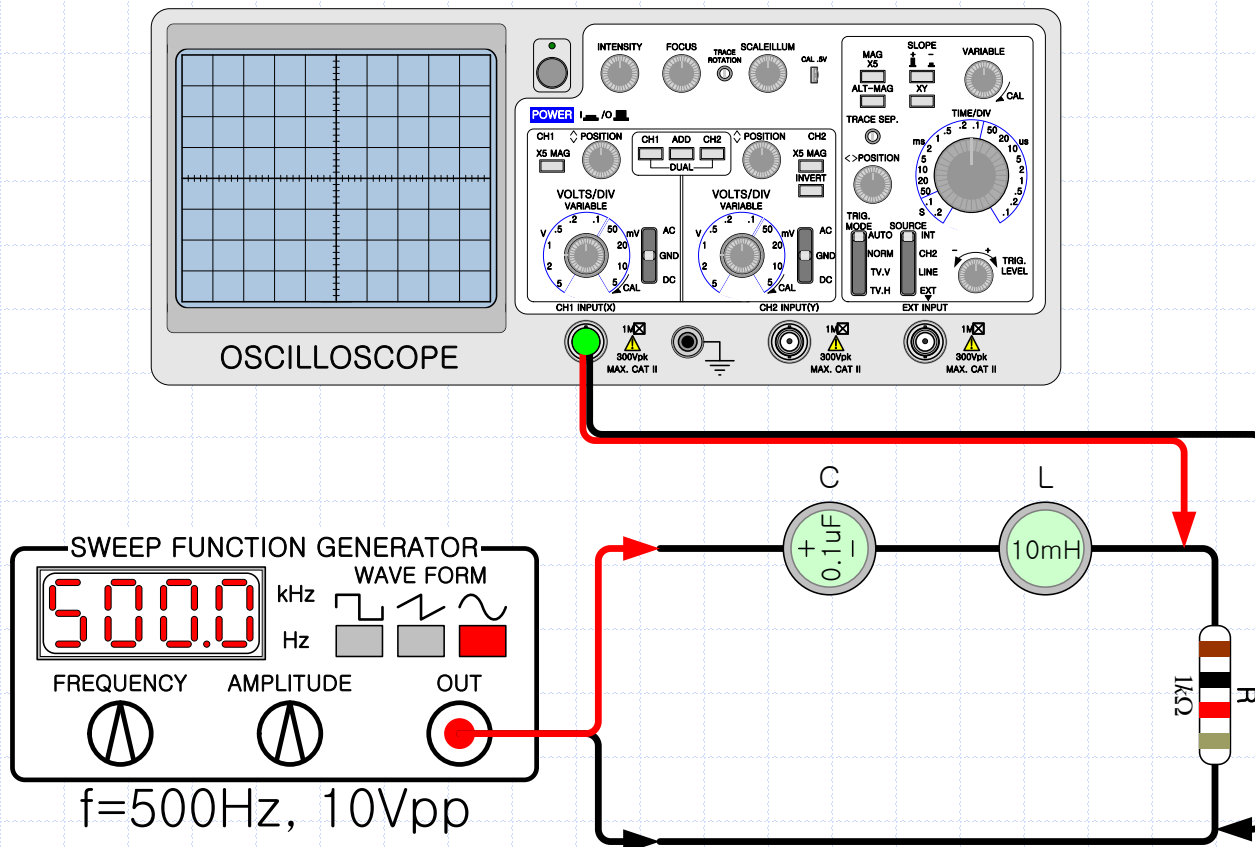

# 14-8. 주파수에 따른 전류 및 임피던스

✓ 주파수 : 500Hz

CH 1

정현파  
500Hz  
10Vpp

GND

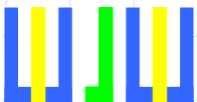
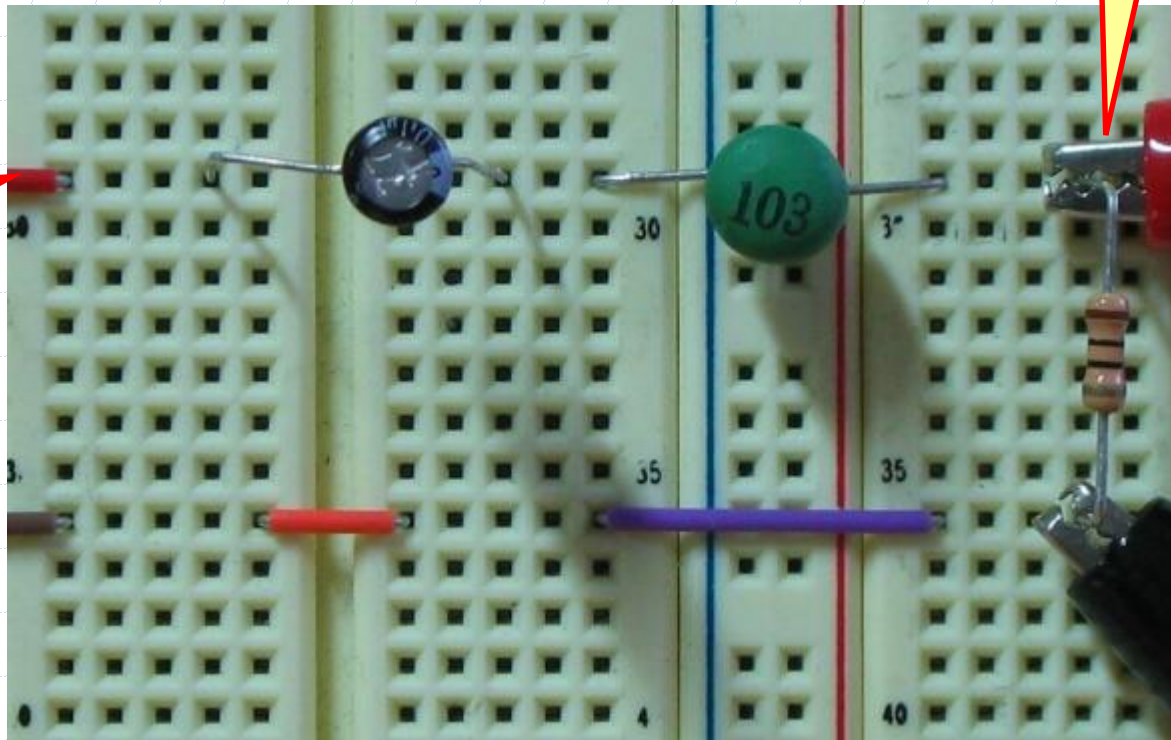

# 14-8. 주파수에 따른 전류 및 임피던스

✓ 주파수 : 500Hz

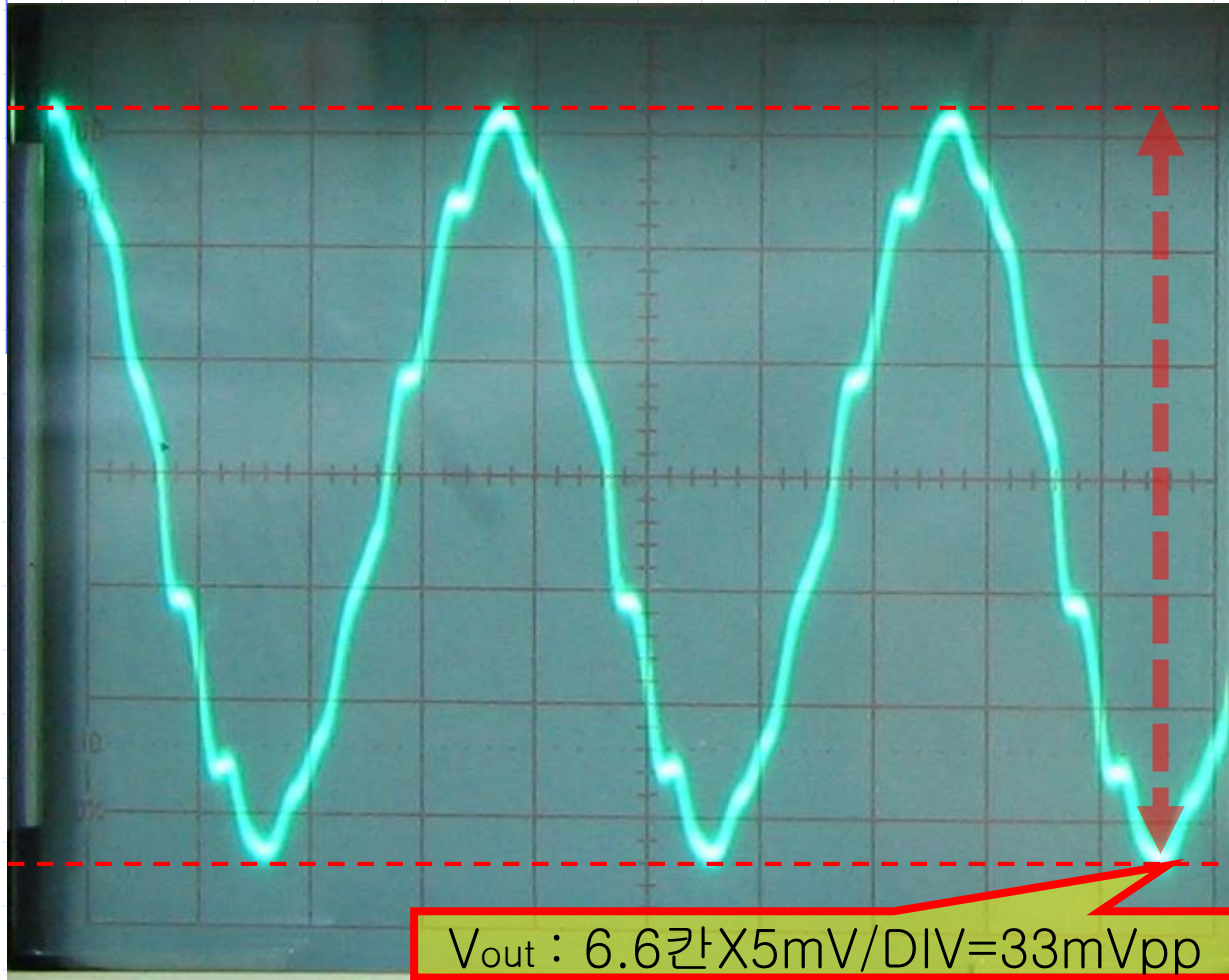

$V_{out} : 6.6 \text{칸} \times 5 \text{mV/DIV} = 33 \text{mV}_{pp}$

CH 1 : 5mV/DIV, Time : 0.5mS/DIV

$$\begin{aligned} I_T &= \frac{V_{10\Omega}}{10\Omega} \\ &= \frac{33 \text{mV}_{PP}}{10\Omega} \\ &= 3.3 \text{mA}_{PP} \end{aligned}$$

$$\begin{aligned} |Z| &= \frac{V_S}{I_T} \\ &= \frac{10 \text{V}_{PP}}{3.3 \text{mA}_{PP}} \\ &= 3030.3\Omega \end{aligned}$$



# 14-8. 주파수에 따른 전류 및 임피던스

✓ 주파수 : 1kHz

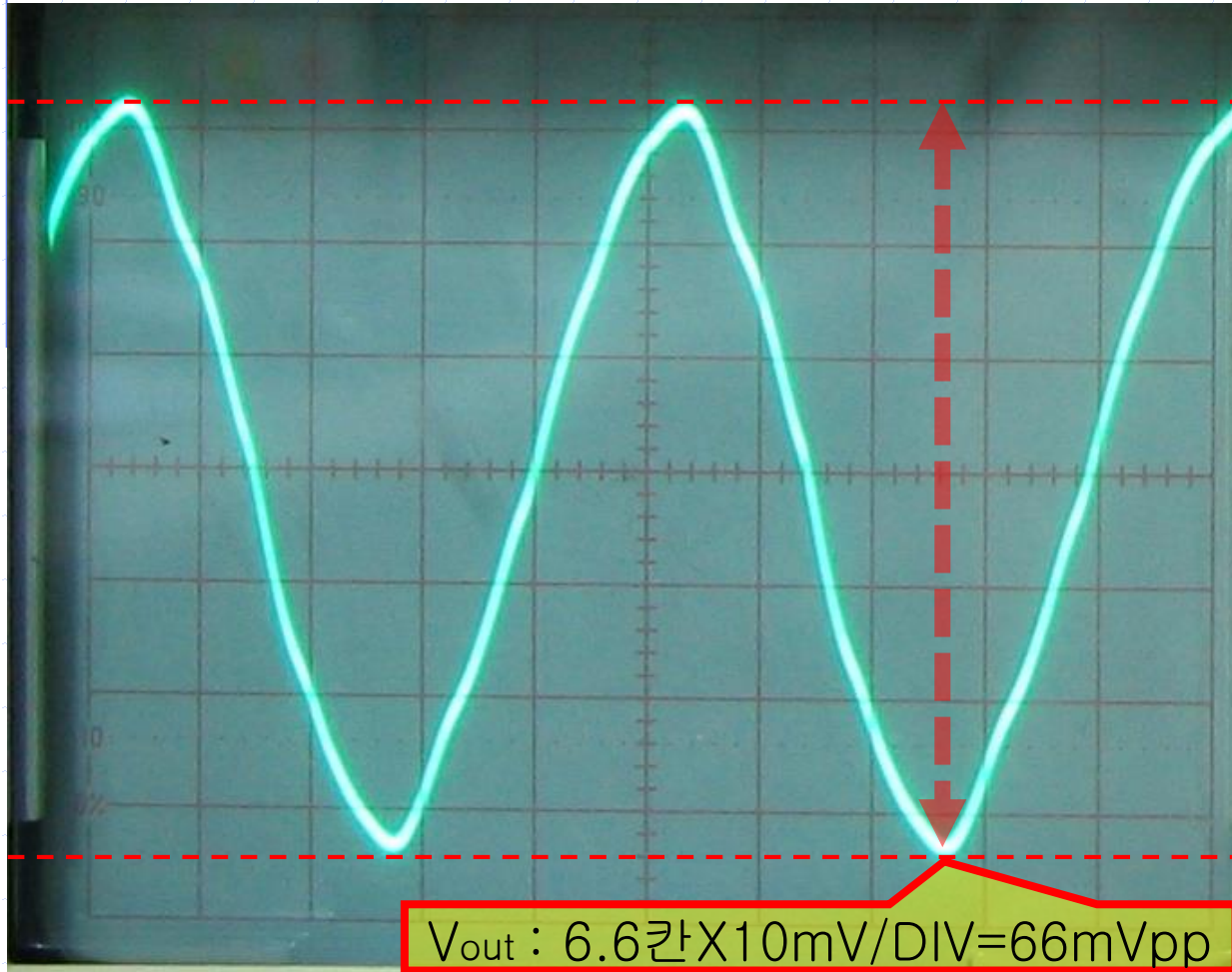

$$\begin{aligned} I_T &= \frac{V_{10\Omega}}{10\Omega} \\ &= \frac{66 \text{mV}_{PP}}{10\Omega} \\ &= 6.6 \text{mA}_{PP} \end{aligned}$$

$$\begin{aligned} |Z| &= \frac{V_S}{I_T} \\ &= \frac{10 \text{V}_{PP}}{6.6 \text{mA}_{PP}} \\ &= 1515.2\Omega \end{aligned}$$

CH 1 : 10mV/DIV, Time : 0.2mS/DIV

# 14-8. 주파수에 따른 전류 및 임피던스

✓ 주파수 : 2kHz

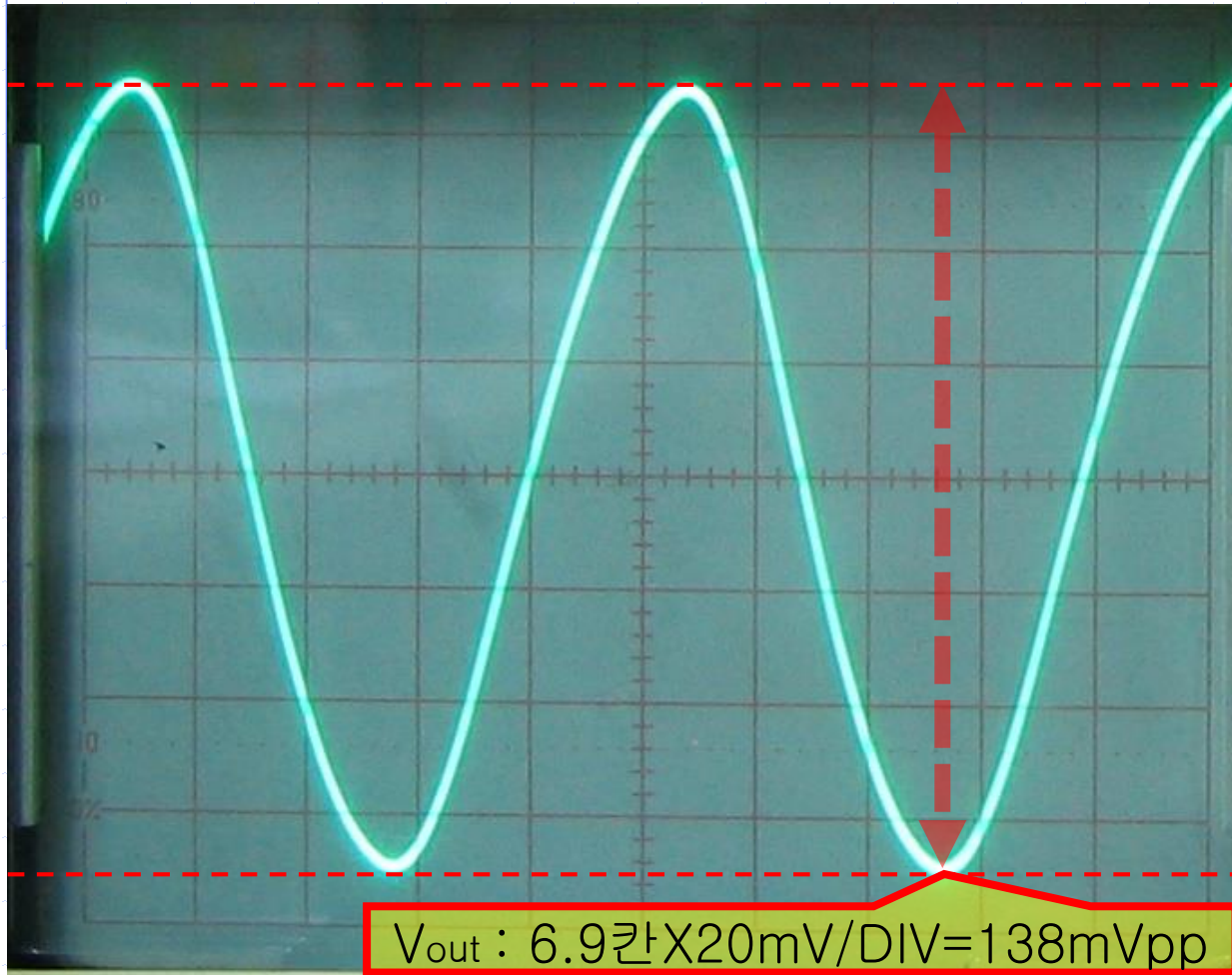

$$\begin{aligned} I_T &= \frac{V_{10\Omega}}{10\Omega} \\ &= \frac{138\text{mV}_{PP}}{10\Omega} \\ &= 13.8\text{mA}_{PP} \end{aligned}$$

$$\begin{aligned} |Z| &= \frac{V_S}{I_T} \\ &= \frac{10V_{PP}}{13.8\text{mA}_{PP}} \\ &= 724.6\Omega \end{aligned}$$

CH 1 : 20mV/DIV, Time : 0.1mS/DIV

# 14-8. 주파수에 따른 전류 및 임피던스

✓ 주파수 : 3kHz

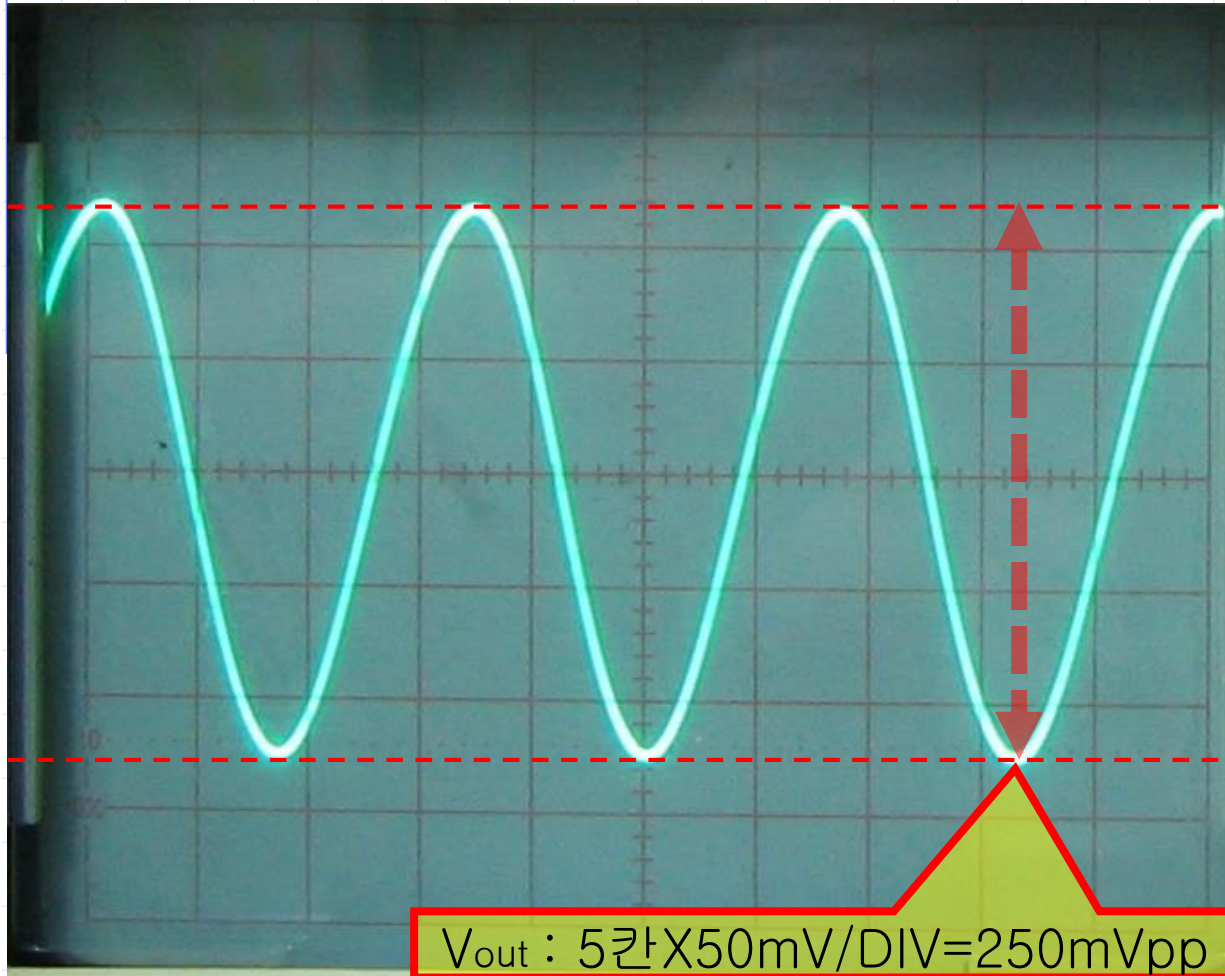

$$\begin{aligned} I_T &= \frac{V_{10\Omega}}{10\Omega} \\ &= \frac{250\text{mV}_{PP}}{10\Omega} \\ &= 25\text{mA}_{PP} \end{aligned}$$

$$\begin{aligned} |Z| &= \frac{V_S}{I_T} \\ &= \frac{10V_{PP}}{25\text{mA}_{PP}} \\ &= 400\Omega \end{aligned}$$

CH 1 : 50mV/DIV, Time : 0.1mS/DIV



# 14-8. 주파수에 따른 전류 및 임피던스

✓ 주파수 : 4kHz

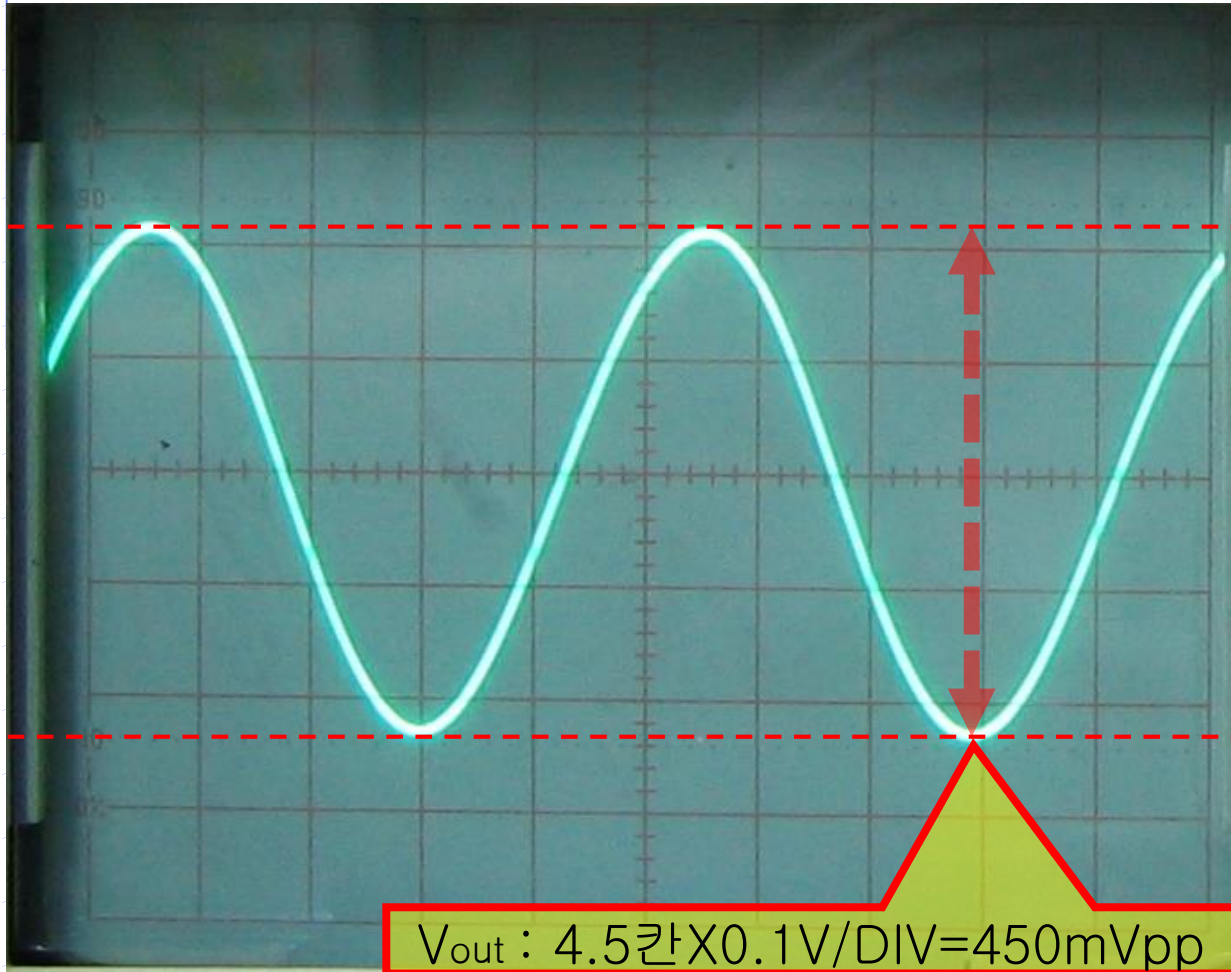

$$\begin{aligned} I_T &= \frac{V_{10\Omega}}{10\Omega} \\ &= \frac{450\text{mV}_{PP}}{10\Omega} \\ &= 45\text{mA}_{PP} \end{aligned}$$

$$\begin{aligned} |Z| &= \frac{V_S}{I_T} \\ &= \frac{10V_{PP}}{45\text{mA}_{PP}} \\ &= 222.2\Omega \end{aligned}$$

CH 1 : 0.1V/DIV, Time : 50uS/DIV



# 14-8. 주파수에 따른 전류 및 임피던스

✓ 주파수 : 5kHz

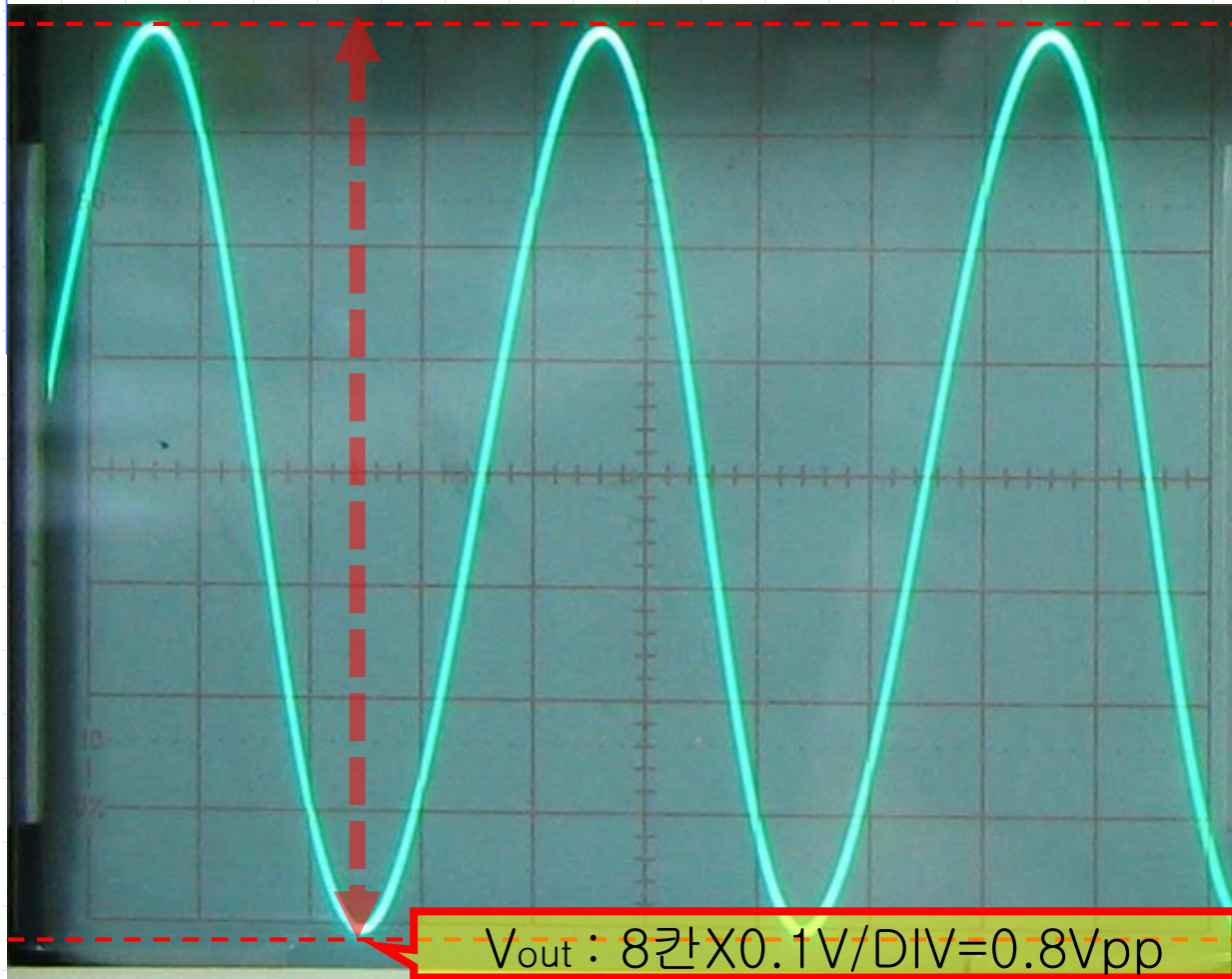

$$\begin{aligned} I_T &= \frac{V_{10\Omega}}{10\Omega} \\ &= \frac{0.8V_{PP}}{10\Omega} \\ &= 80mA_{PP} \end{aligned}$$

$$\begin{aligned} |Z| &= \frac{V_S}{I_T} \\ &= \frac{10V_{PP}}{80mA_{PP}} \\ &= 127.8\Omega \end{aligned}$$

CH 1 : 0.1V/DIV, Time : 50uS/DIV

# 14-8. 주파수에 따른 전류 및 임피던스

✓ 주파수 : 공진주파수(5.032kHz)

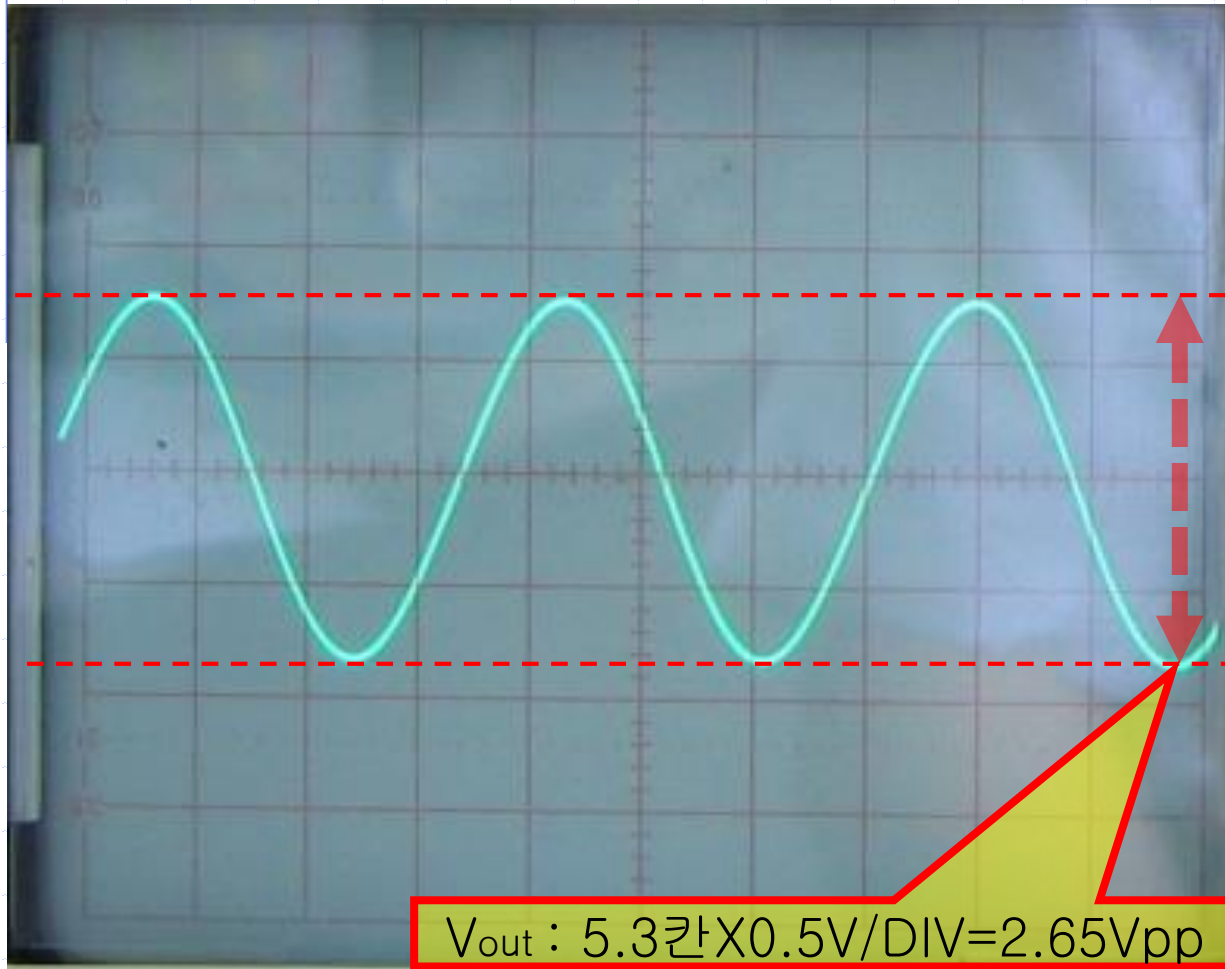

$V_{out} : 5.3\text{칸} \times 0.5\text{V/DIV} = 2.65\text{V}_{pp}$

CH 1 : 0.5V/DIV, Time : 50uS/DIV

$$\begin{aligned} I_T &= \frac{V_{10\Omega}}{10\Omega} \\ &= \frac{2.65V_{PP}}{10\Omega} \\ &= 265\text{mA}_{PP} \end{aligned}$$

$$\begin{aligned} |Z| &= \frac{V_S}{I_T} \\ &= \frac{10V_{PP}}{80\text{mA}_{PP}} \\ &= 37.7\Omega \end{aligned}$$

# 14-8. 주파수에 따른 전류 및 임피던스

✓ 주파수 : 6kHz

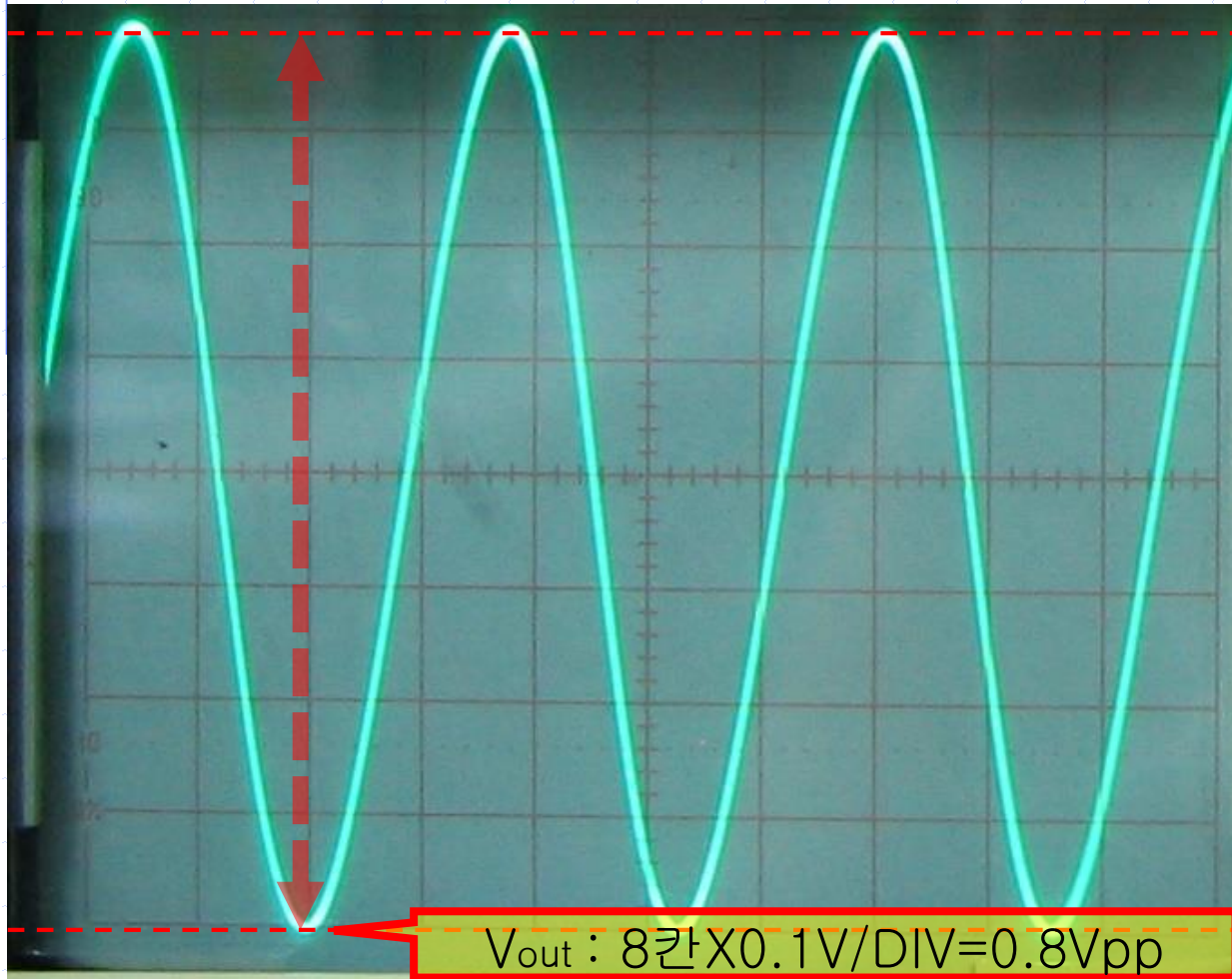

$$\begin{aligned} I_T &= \frac{V_{10\Omega}}{10\Omega} \\ &= \frac{0.8V_{PP}}{10\Omega} \\ &= 80mA_{PP} \end{aligned}$$

$$\begin{aligned} |Z| &= \frac{V_S}{I_T} \\ &= \frac{10V_{PP}}{80mA_{PP}} \\ &= 127.8\Omega \end{aligned}$$

CH 1 : 0.1V/DIV, Time : 50uS/DIV

# 14-8. 주파수에 따른 전류 및 임피던스

✓ 주파수 : 7kHz

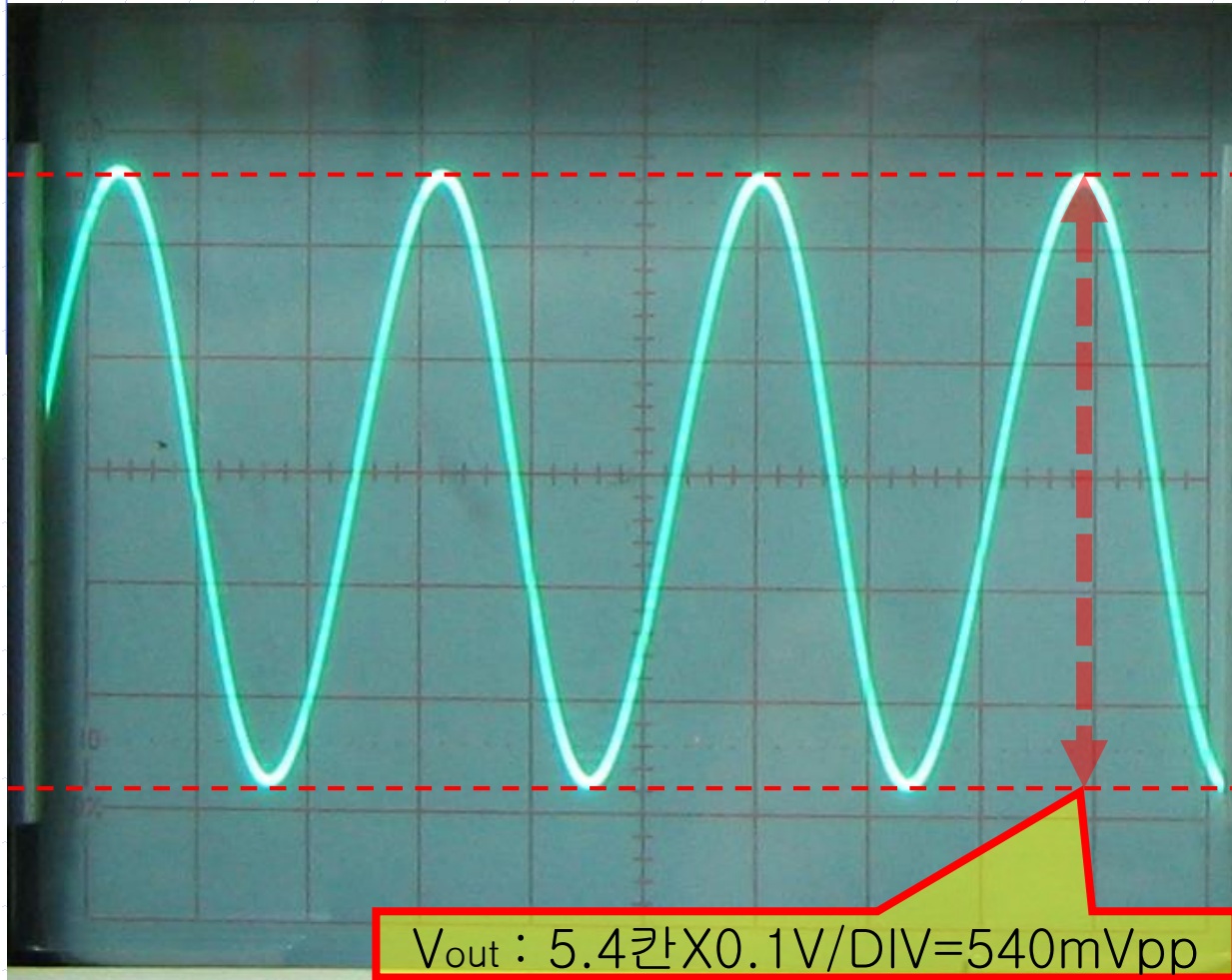

$$\begin{aligned} I_T &= \frac{V_{10\Omega}}{10\Omega} \\ &= \frac{540 \text{mV}_{PP}}{10\Omega} \\ &= 54 \text{mA}_{PP} \end{aligned}$$

$$\begin{aligned} |Z| &= \frac{V_S}{I_T} \\ &= \frac{10 \text{V}_{PP}}{54 \text{mA}_{PP}} \\ &= 185.2\Omega \end{aligned}$$

CH 1 : 0.1V/DIV, Time : 50uS/DIV



# 14-8. 주파수에 따른 전류 및 임피던스

✓ 주파수 : 8kHz

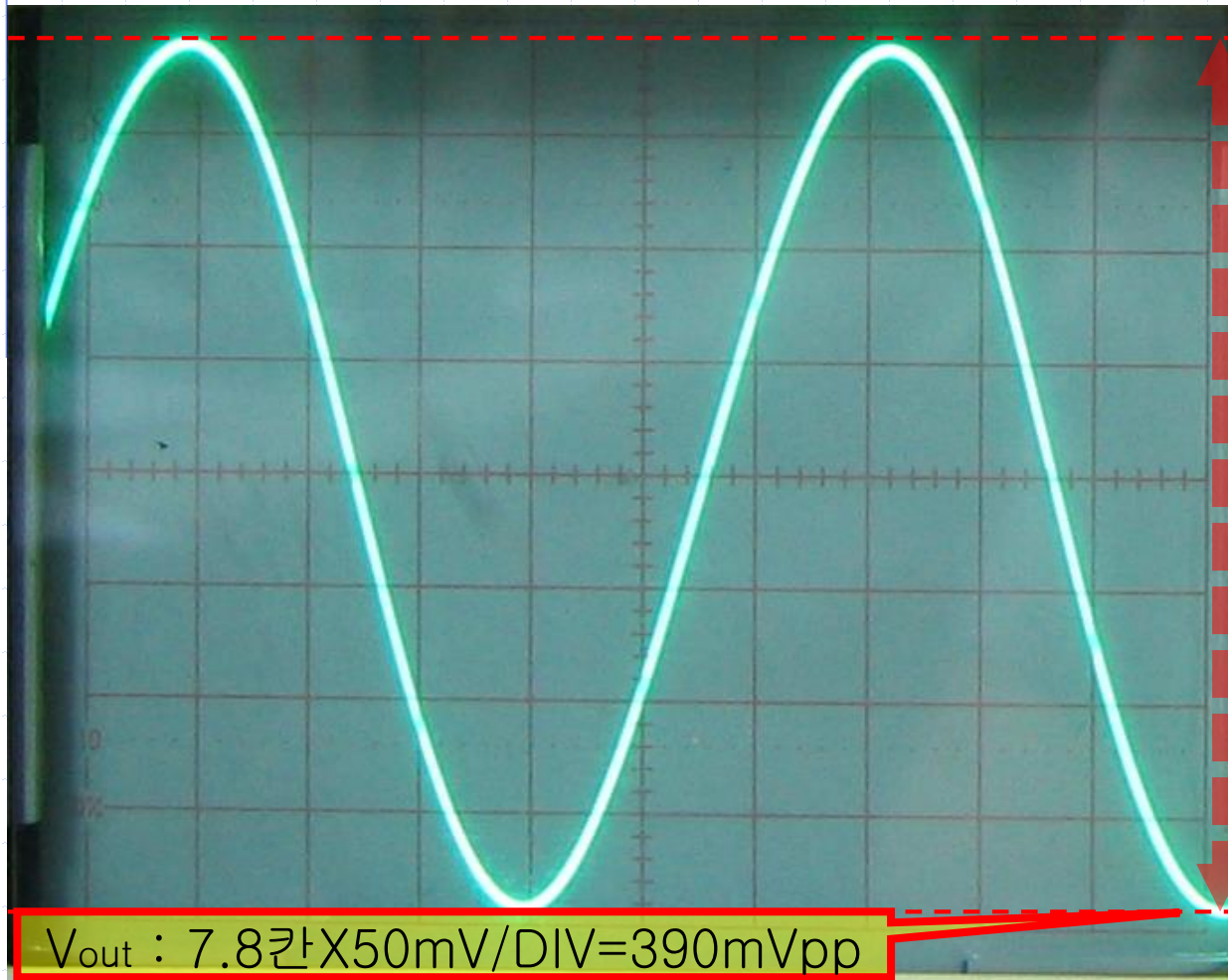

$$\begin{aligned} I_T &= \frac{V_{10\Omega}}{10\Omega} \\ &= \frac{390\text{mV}_{PP}}{10\Omega} \\ &= 39\text{mA}_{PP} \end{aligned}$$

$$\begin{aligned} |Z| &= \frac{V_S}{I_T} \\ &= \frac{10V_{PP}}{39\text{mA}_{PP}} \\ &= 256.4\Omega \end{aligned}$$

CH 1 : 50mV/DIV, Time : 20uS/DIV

# 14-8. 주파수에 따른 전류 및 임피던스

✓ 주파수 : 9kHz

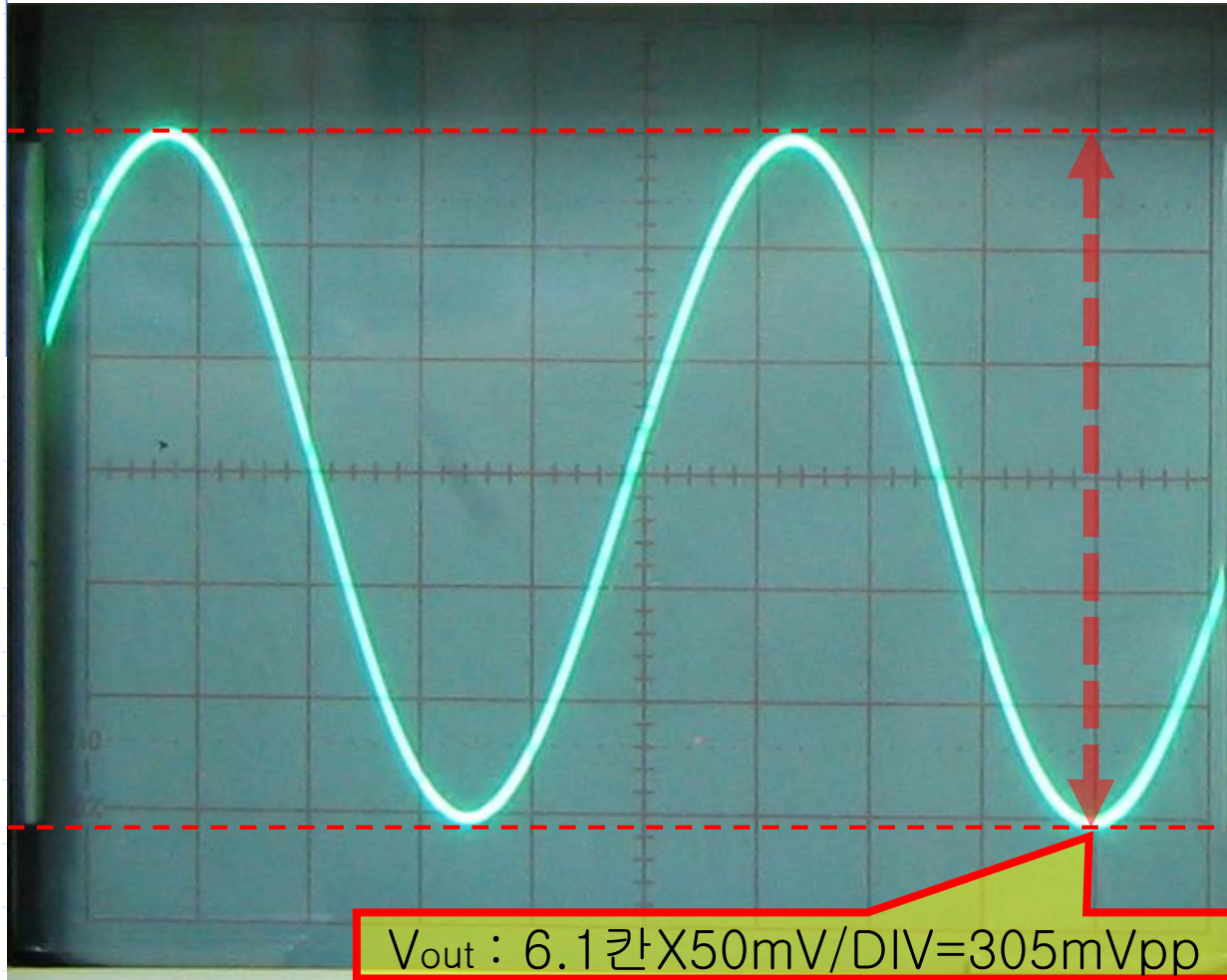

$$\begin{aligned} I_T &= \frac{V_{10\Omega}}{10\Omega} \\ &= \frac{305 \text{ mV}_{PP}}{10\Omega} \\ &= 30.5 \text{ mA}_{PP} \end{aligned}$$

$$\begin{aligned} |Z| &= \frac{V_S}{I_T} \\ &= \frac{10 \text{ V}_{PP}}{30.5 \text{ mA}_{PP}} \\ &= 327.9\Omega \end{aligned}$$

CH 1 : 50mV/DIV, Time : 20uS/DIV

# 14-8. 주파수에 따른 전류 및 임피던스

✓ 주파수 : 10kHz

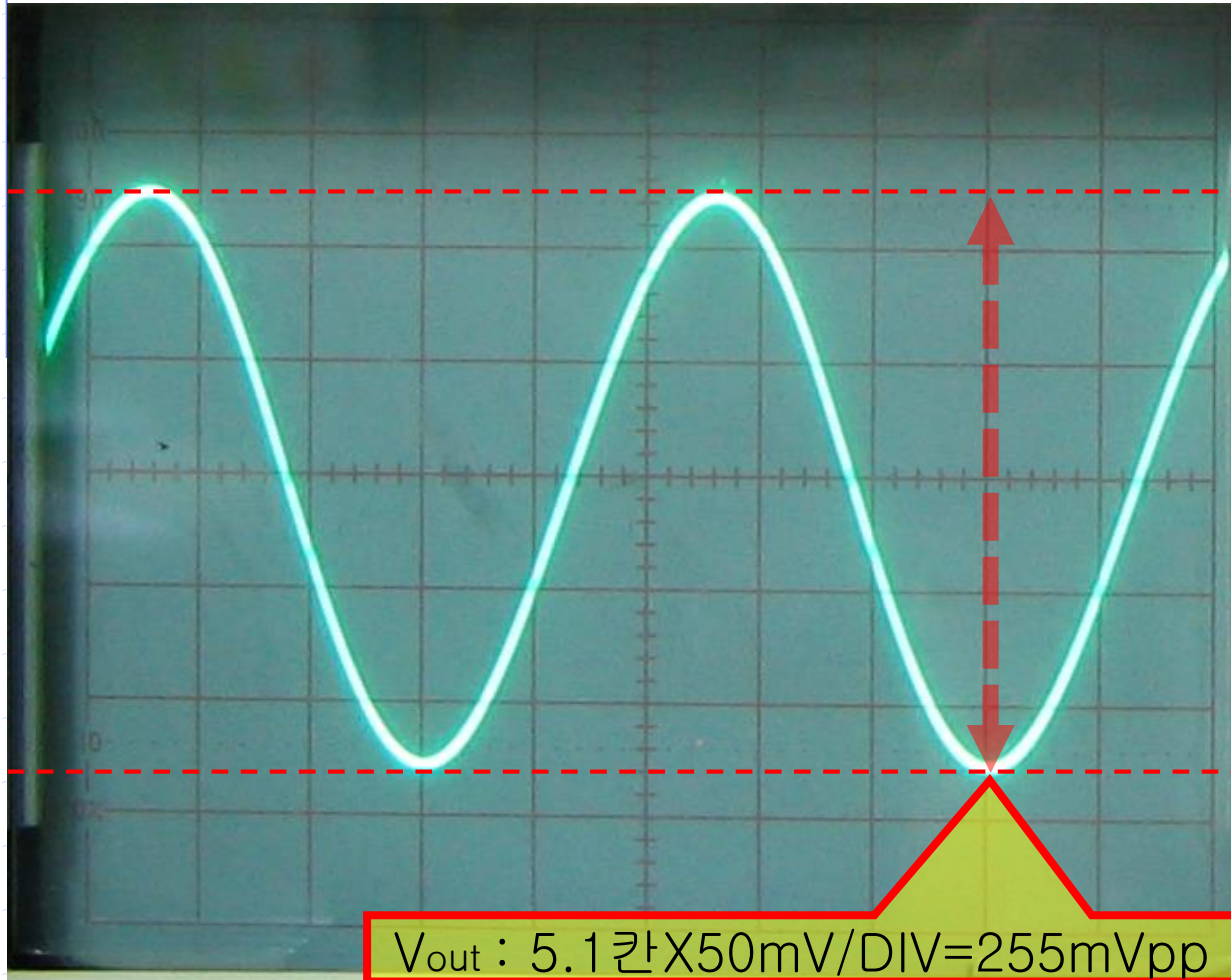

$$\begin{aligned} I_T &= \frac{V_{10\Omega}}{10\Omega} \\ &= \frac{255 \text{mV}_{PP}}{10\Omega} \\ &= 25.5 \text{mA}_{PP} \end{aligned}$$

$$\begin{aligned} |Z| &= \frac{V_S}{I_T} \\ &= \frac{10 \text{V}_{PP}}{25.5 \text{mA}_{PP}} \\ &= 392.2\Omega \end{aligned}$$

CH 1 : 50mV/DIV, Time : 20uS/DIV



# 14-8. 주파수에 따른 전류 및 임피던스

✓ 주파수 : 15kHz

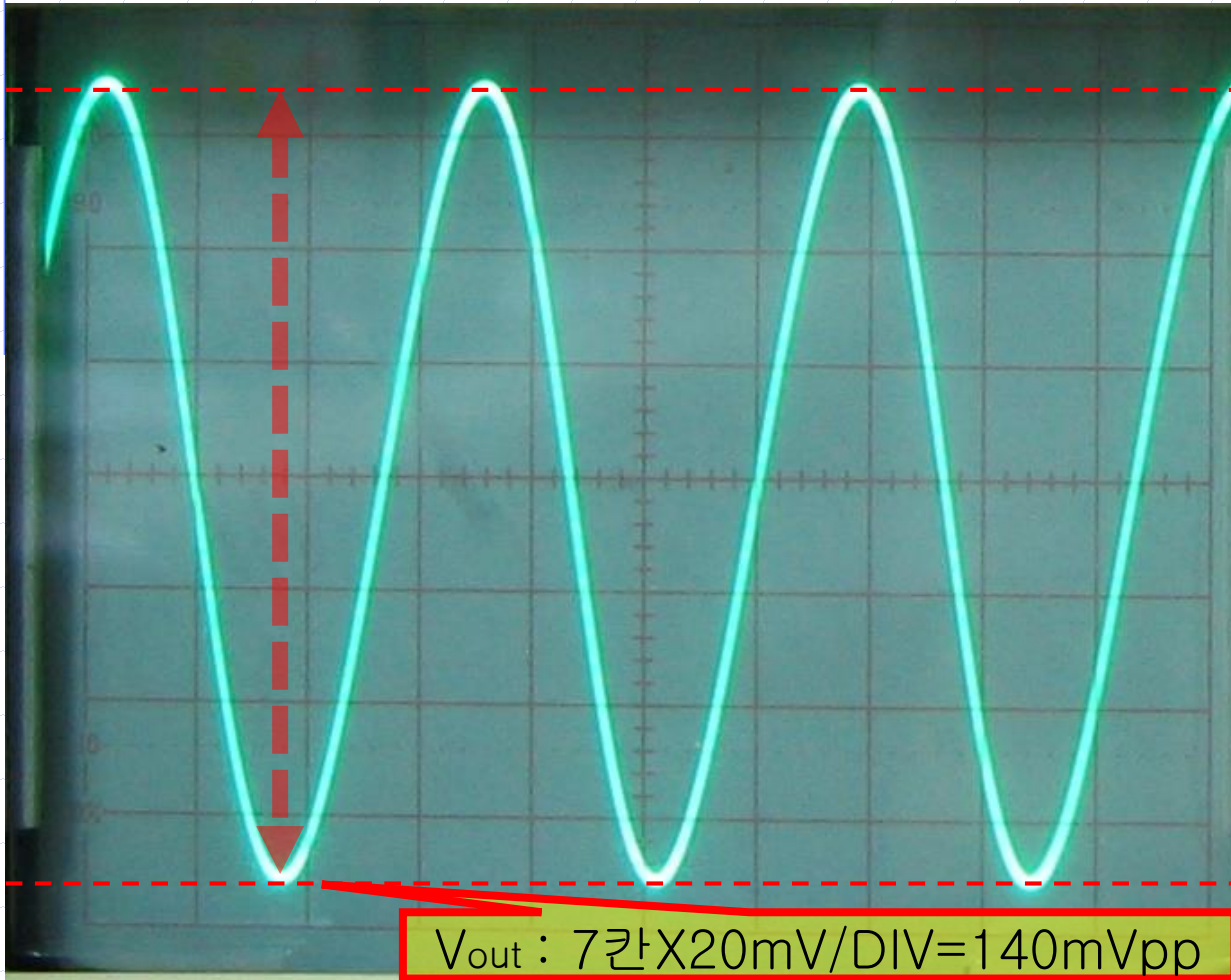

$V_{out} : 7\text{칸} \times 20\text{mV/DIV} = 140\text{mV}_{pp}$

CH 1 : 20mV/DIV, Time : 20uS/DIV

$$\begin{aligned} I_T &= \frac{V_{10\Omega}}{10\Omega} \\ &= \frac{140\text{mV}_{PP}}{10\Omega} \\ &= 14\text{mA}_{PP} \end{aligned}$$

$$\begin{aligned} |Z| &= \frac{V_S}{I_T} \\ &= \frac{10V_{PP}}{14\text{mA}_{PP}} \\ &= 714.3\Omega \end{aligned}$$





# 14-8. 주파수에 따른 전류 및 임피던스

✓ 주파수 : 20kHz

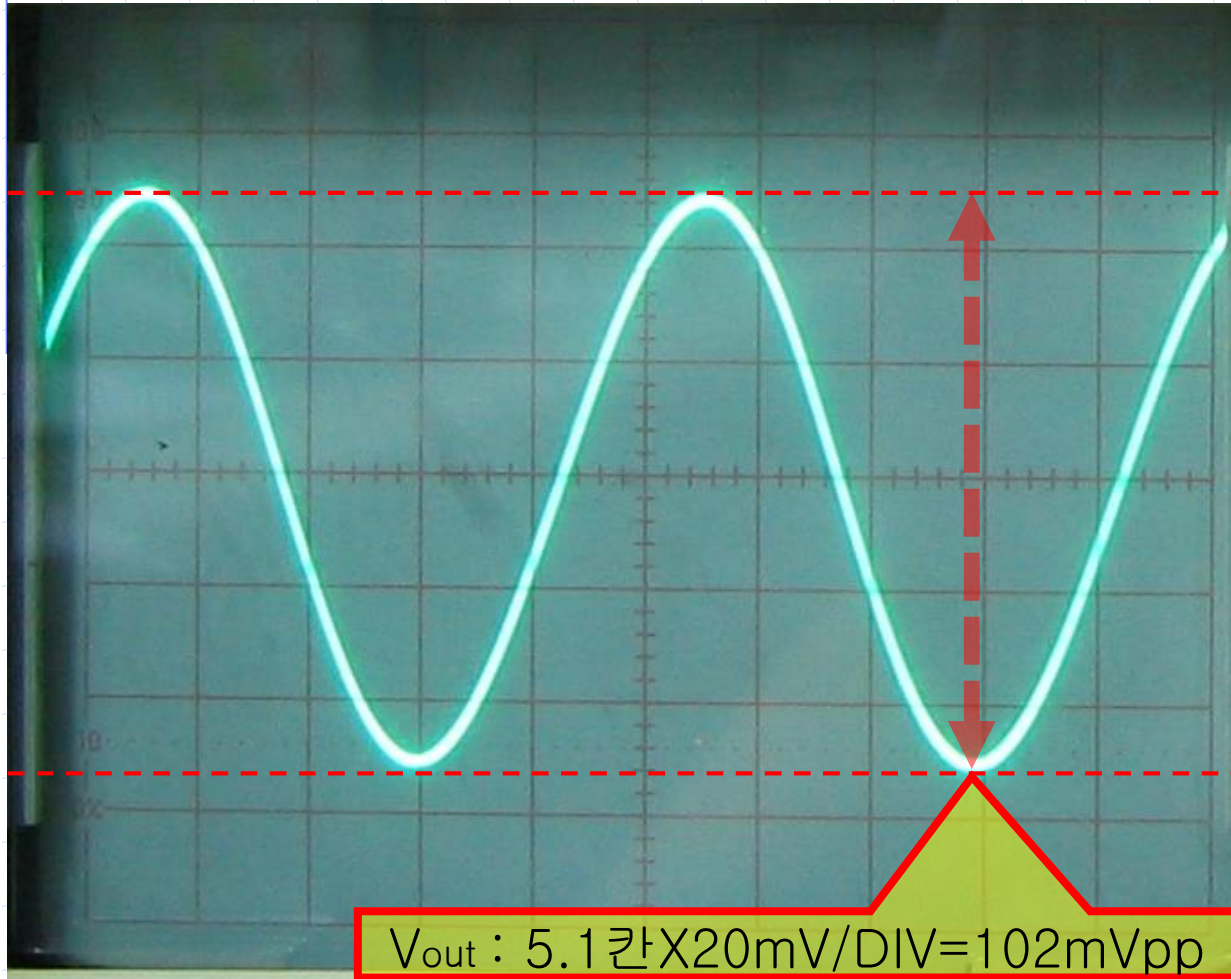

$$\begin{aligned} I_T &= \frac{V_{10\Omega}}{10\Omega} \\ &= \frac{102 \text{mV}_{PP}}{10\Omega} \\ &= 10.2 \text{mA}_{PP} \end{aligned}$$

$$\begin{aligned} |Z| &= \frac{V_S}{I_T} \\ &= \frac{10 \text{V}_{PP}}{10.2 \text{mA}_{PP}} \\ &= 980.4\Omega \end{aligned}$$

CH 1 : 20mV/DIV, Time : 10uS/DIV

# 14-8. 주파수에 따른 전류 및 임피던스

✓ 주파수 : 30kHz

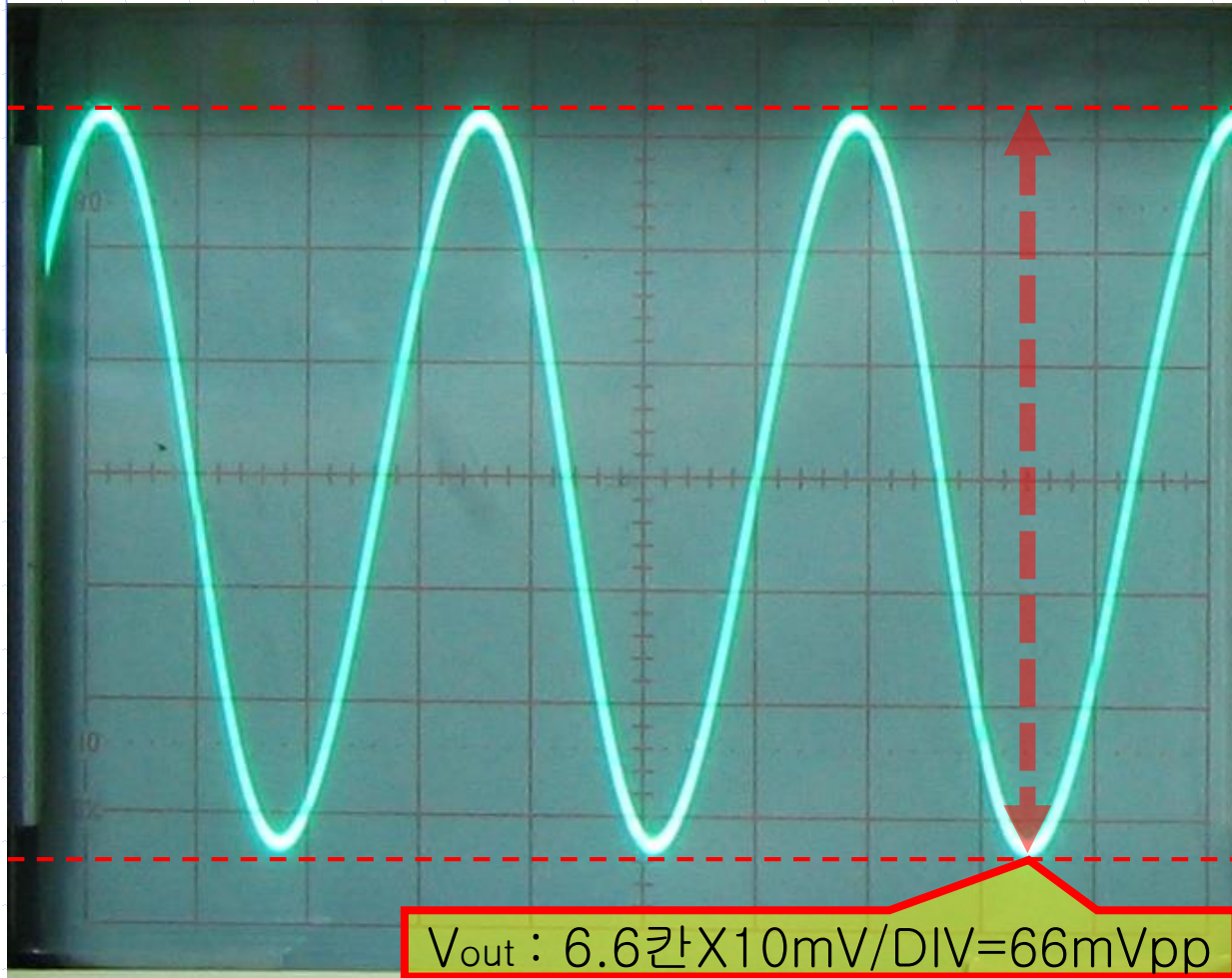

$$\begin{aligned} I_T &= \frac{V_{10\Omega}}{10\Omega} \\ &= \frac{66 \text{mV}_{PP}}{10\Omega} \\ &= 6.6 \text{mA}_{PP} \end{aligned}$$

$$\begin{aligned} |Z| &= \frac{V_S}{I_T} \\ &= \frac{10 \text{V}_{PP}}{6.6 \text{mA}_{PP}} \\ &= 1515.1\Omega \end{aligned}$$

CH 1 : 10mV/DIV, Time : 10uS/DIV

# 14-8. 주파수에 따른 전류 및 임피던스

✓ 주파수 : 40kHz

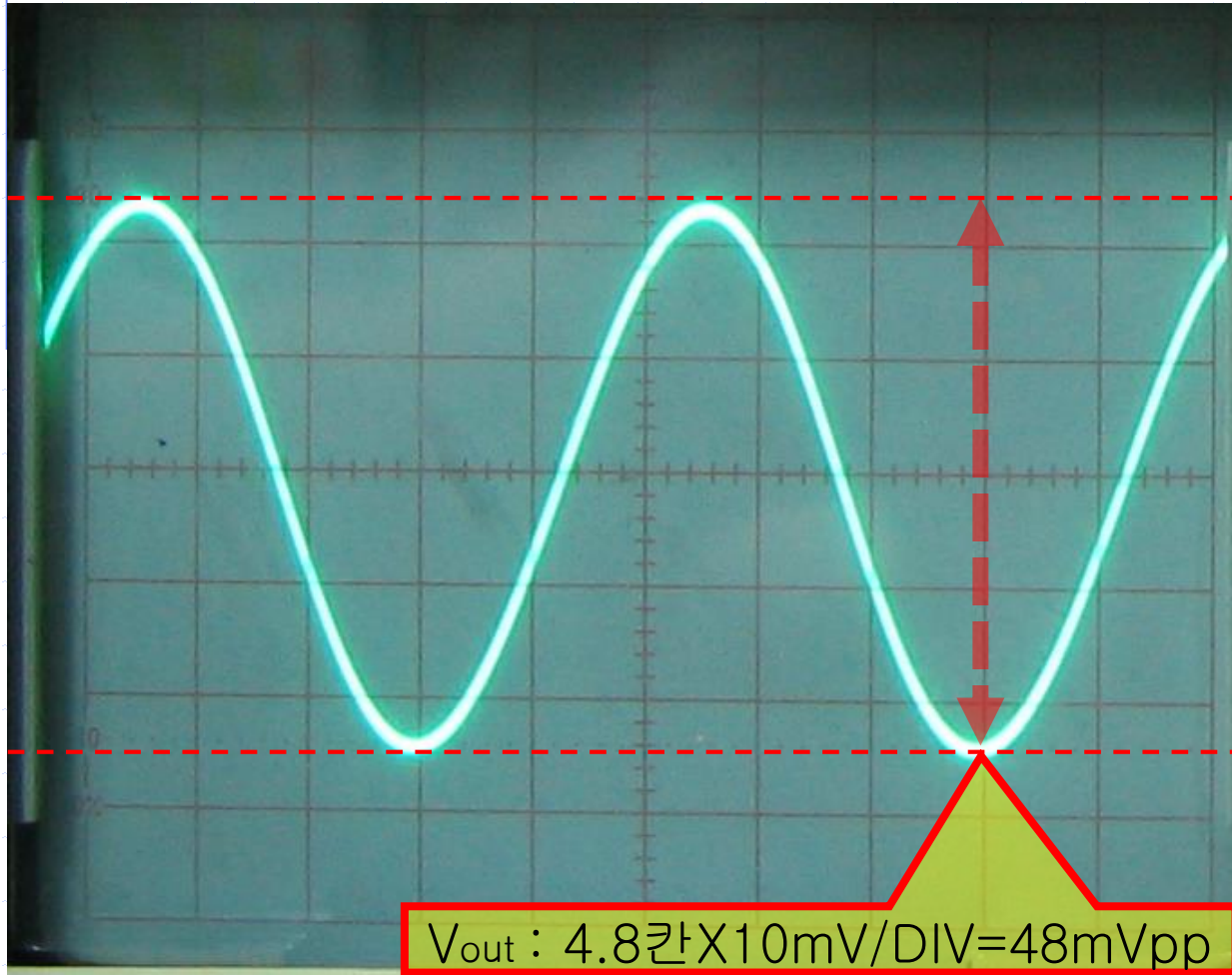

$$\begin{aligned} I_T &= \frac{V_{10\Omega}}{10\Omega} \\ &= \frac{48 \text{mV}_{PP}}{10\Omega} \\ &= 4.8 \text{mA}_{PP} \end{aligned}$$

$$\begin{aligned} |Z| &= \frac{V_S}{I_T} \\ &= \frac{10 \text{V}_{PP}}{4.8 \text{mA}_{PP}} \\ &= 2083.3\Omega \end{aligned}$$

CH 1 : 10mV/DIV, Time : 5uS/DIV



# 14-8. 주파수에 따른 전류 및 임피던스

✓ 주파수 : 50kHz

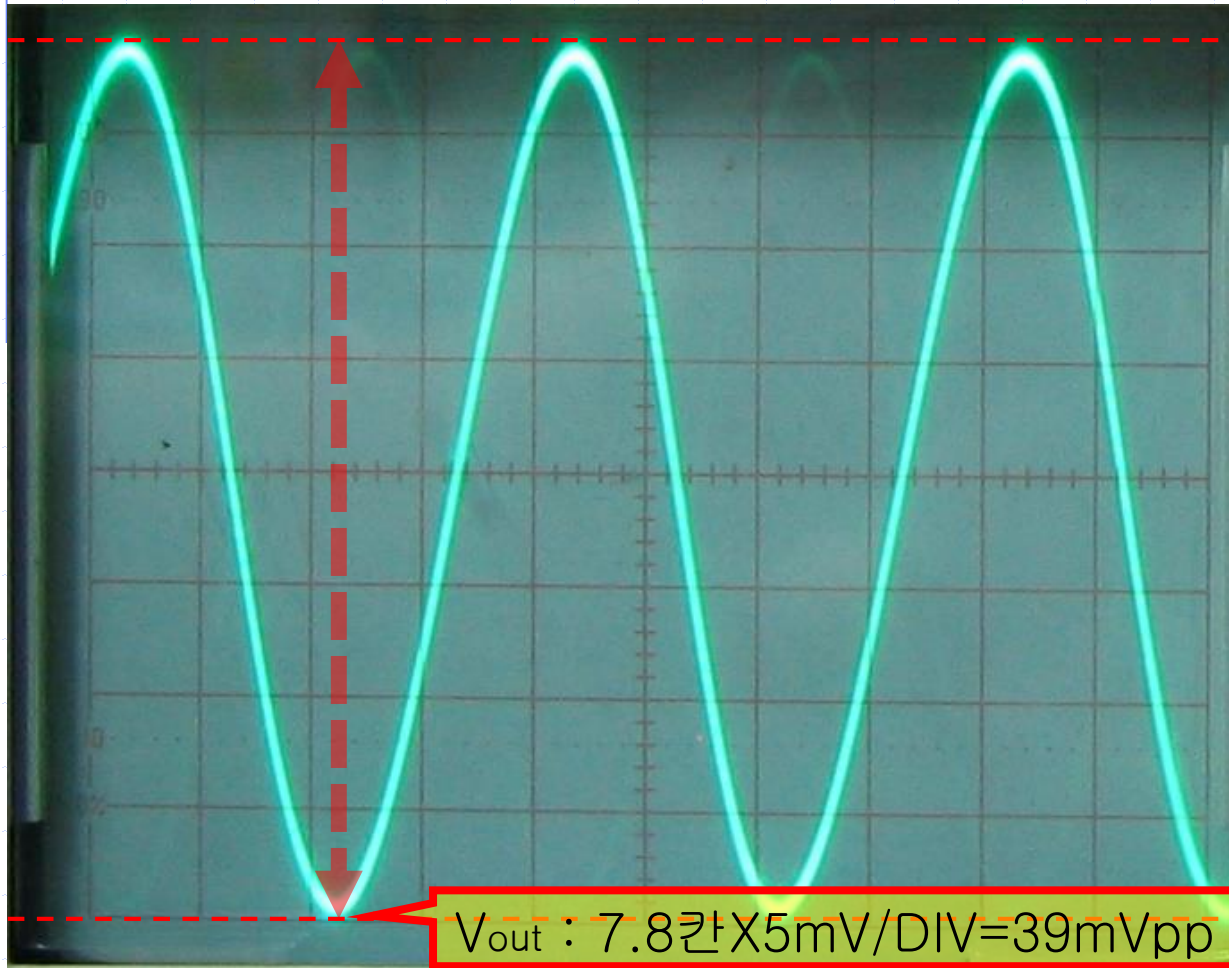

$$\begin{aligned} I_T &= \frac{V_{10\Omega}}{10\Omega} \\ &= \frac{39\text{mV}_{PP}}{10\Omega} \\ &= 3.9\text{mA}_{PP} \end{aligned}$$

$$\begin{aligned} |Z| &= \frac{V_S}{I_T} \\ &= \frac{10V_{PP}}{3.9\text{mA}_{PP}} \\ &= 2564.1\Omega \end{aligned}$$

CH 1 : 5mV/DIV, Time : 5uS/DIV



# 14-8. 주파수에 따른 전류 및 임피던스

